

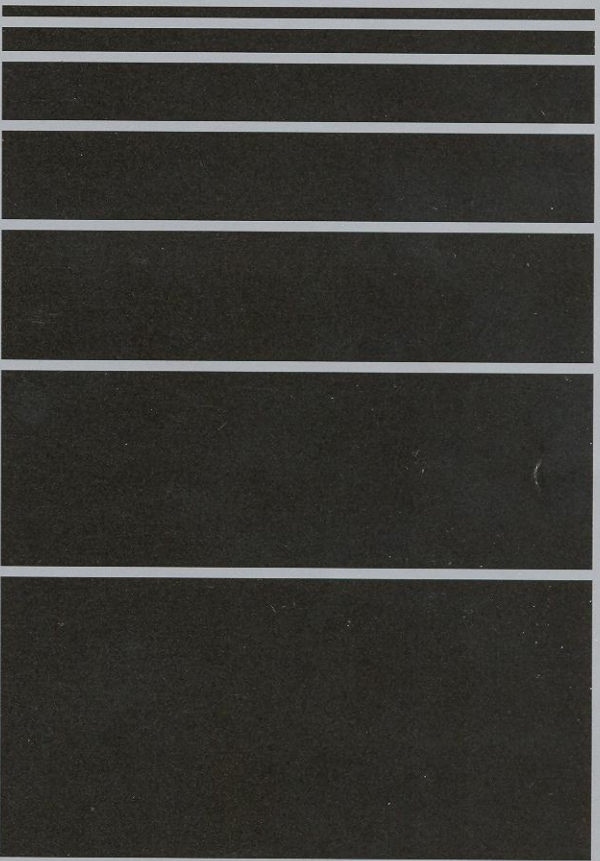

# AIRIDE<sup>®</sup> DESIGN GUIDE



SUSPENSION APPLICATIONS



**Firestone**  
World's Number 1  
Air Spring. 

FIRESTONE INDUSTRIAL PRODUCTS COMPANY



## TABLE OF CONTENTS

### PLEASE NOTE

The information contained in this publication is intended to provide a general guide to the characteristics and applications of these products. The material, herein, was developed through engineering design and development, testing and actual applications and is believed to be reliable and accurate. However, Firestone makes no warranty, express or implied, of this information. Anyone making use of this material does so at his own risk and assumes all liability resulting from such use. It is suggested that competent professional assistance be employed for specific applications.

1 Advantages	3
2 Terms - Air Springs & Suspensions	5
3 Types Of Air Springs	9
4 How To Use The Product Data Sheets	23
5 Application Considerations	33
6 Basic Principles (Derivation of Formulas)	37
7 Sample Calculations: Air Springs & Suspensions	49
8 Sample Calculations: Using A Personal Computer	63
9 Warranty Considerations	71

## **HISTORY**

In the early 1930's, the Firestone Tire and Rubber Company began experiments to develop the potential of pneumatic springs.

Between 1935 and 1939, several makes of U.S. automobiles were equipped with air springs and extensively tested to prove the potential of automotive air suspension systems. They were never put into production, however, because significant developments in steel spring design gave an improved ride at much lower cost than the air spring system at that time.

In 1938, the country's largest manufacturer of motor coaches became interested in using air springs on a new design bus they were developing. Working with Firestone engineers, the first busses were tested in 1944 and the inherent ride superiority of air suspensions was clearly documented.

In the early 1950's, after several years of intensive product development, the air sprung bus finally went into production. That was the beginning of the Airide® air spring success story.

The success of air springs in bus applications spurred new interest in truck and trailer applications as well as industrial shock and vibration isolation uses. Consequently, almost all of the busses, most of the Class 8 trucks and many of the trailers on the road today now ride on air springs, and significant advances in the design of control systems have opened the door to automotive applications as well.



## ADVANTAGES

### **AIR SPRINGS GIVE FLEETS A COMPETITIVE EDGE**

Today's trucking industry has become far more efficient than ever before. In many cases it's a matter of survival. That's why more and more fleets are specifying air suspensions for their new trucks and trailers.

It is a well documented fact that trucks and trailers with air suspensions suffer much less "wear and tear" than those that ride on steel. This means longer cab and vehicle life, lower operating costs, less down time and fewer failures of expensive on-board electronic equipment.

It's also a fact that when trucks ride better, so does the cargo. Trucks and trailers equipped with air suspensions experience substantially less cargo damage (and fewer damage claims) than those with conventional suspensions.

Aside from the obvious economic benefits of air suspensions, driver comfort has become one of the most important benefits of all. Recruiting and keeping good drivers has become a major problem in the trucking industry. With air suspensions, drivers are more comfortable, more productive and less subject to accidents caused by fatigue. They are also a lot happier. Drivers have always preferred air suspensions. Today they demand them.

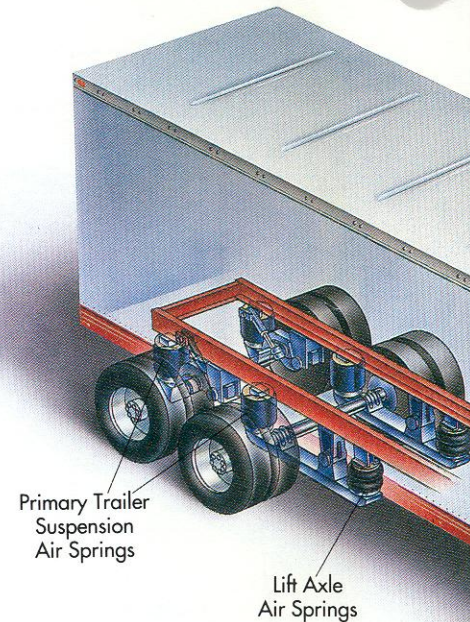

Fleets that invest in air suspensions are making a very smart business decision. After saving thousands of dollars in reduced maintenance costs and less vehicle down time, they pay back the original investment in hard cash at trade-in time. Year by year, and model for model, used tractors and trailers with air suspensions are worth much more than those with steel suspensions.

### **NOTHING ADDS MORE VALUE TO TRAILERS THAN AIR SUSPENSIONS**

To be competitive today, fleets have to be flexible. They can't afford to run their trailers empty. With an air suspension system, you can haul just about anything. You can haul steel castings on the outbound run and bring back a load of watermelons or fragile electronics on the return trip . . . eliminating those costly empty trailer miles.

And, because you get almost perfect load equalization between axles, you can always run at the legal limits. Another benefit is the elimination of "cargo shift." With an air suspension system, cargo stays where you put it. There's never a lopsided condition due to unequal weight distribution.

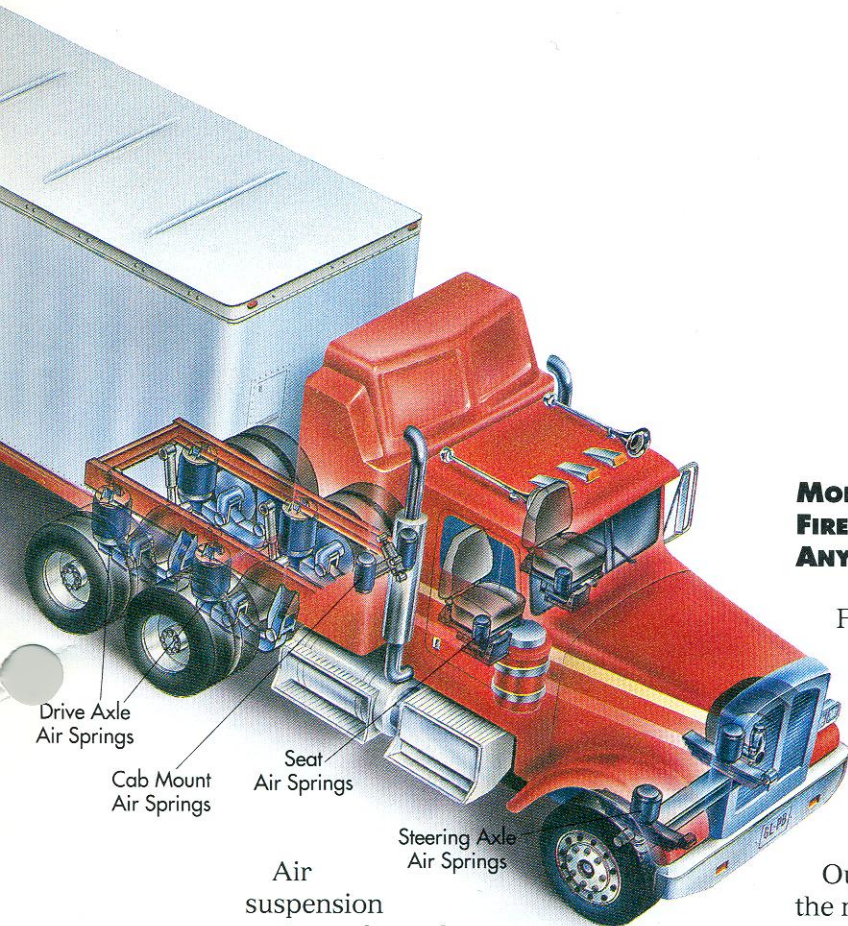

**MORE SUSPENSION BUILDERS USE  
FIRESTONE AIRIDE® AIR SPRINGS THAN  
ANY OTHER BRAND**

Firestone created a revolution in the transportation industry when it introduced the *Airide* air spring in 1934. Since that time, we have designed and manufactured more air springs for more applications than any other air spring company in the world.

Our company is totally dedicated to the manufacture of air springs. They make up over 90% of our business. Our sales representatives have a thorough understanding of the needs of air suspension builders and fleet owners. That's one of the reasons why the technical support we give to our customers is unrivaled.

But the real test is on the road, where the "Airide Advantage" is challenged, tested and proven every day on thousands of tractors and trailers all over the world. That's where our brand has earned the right to be called "World's Number 1 Air Spring."

And that's why more truck, trailer and bus suspension builders specify genuine Firestone *Airide* air springs than any other brand.

Air suspension systems also reduce operating costs by reducing maintenance and increasing the life of the trailer.

Firestone *Airide*® air springs isolate the destructive shock inputs from the road surface. That means less wheel hop and longer life for the trailer (and tractor). Deadheading tankers and flat beds take much less punishment, and electrical, reefer unit and upper coupler problems are greatly reduced, to mention a few. There are also fewer problems with door seals, latches, hinges, wiring and light bulbs.

The truth is, nothing offers a greater payback than air suspensions for trailers. You get a trailer that lasts longer, a better ride for the cargo, much greater hauling flexibility, less time in the shop and more time on the road.



## TERMS - AIR SPRINGS & SUSPENSIONS

### PRESSURE & PROCESS TERMS

**Absolute Pressure.** The pressure in a vessel located in a complete vacuum. Usually determined by adding 14.7 to the gauge pressure. Absolute pressure = gauge pressure + atmospheric pressure.

**Adiabatic Process.** All the calculation variables, volume, pressure, and temperature, change without any heat transfer (not often a real life situation).

**Atmospheric Pressure.** The average atmospheric air pressure measured at sea level. Normally accepted to be 14.7 pounds per square inch (psi).

**Constant Volume With Airflow Process.** Volume and temperature constant, pressure changes. This condition applies when load is added or removed from above the air spring over a period of time.

**Gauge Pressure.** Gas or liquid pressure in a vessel, which is higher than atmospheric pressure. Usually measured by a Bourdon tube gauge in pounds per square inch (psi).

**Polytropic Process.** All the calculation variables, volume, pressure, and tem-

perature, change with heat transfer to the air spring structure. To account for this, air spring dynamic operation is calculated by the use of what is known as the polytropic exponent (n).  $n = 1.38$  is the generally accepted value for air springs.

### AIR SPRING COMPONENT TERMS

**Bead.** A part of the flexible member that locks the cord structure to an inside reinforcing metal ring and provides a means of sealing the joint between the flexible member and the adjacent structure.

**Bead Plate.** A metal plate closing the top end of the flexible member. It is attached to the flexible member by crimping. It has studs, blind nuts, brackets, or pins to facilitate its attachment to the vehicle structure. A means of supplying air to the assembly is provided as a separate fitting or in combination with an attachment stud. Convolute type springs incorporate a second bead plate on the bottom to create an air tight unit and to provide a means of fastening the unit to the suspension.

**Bead Ring.** A metal ring incorporating a shaped cross-section that grips the bead of the flexible member and provides a means of attaching and sealing the bead to a plate or other structure.

**Bumper.** Usually, these are made of rubber, plastic, or rubber and fabric materials. They are used to support the vehicle when there is no air in the air springs, when the vehicle is not in use, or when there is a system failure on the road. They will also, to some degree, cushion the shock of very severe axle force inputs to prevent damage to both the Airide® spring assembly and to the vehicle.

**Clamp Ring.** A metal band placed near the end of a beadless flexible member. It is swaged tightly in place to secure the beadless flexible member to the upper end cap and piston.

**Flexible Member.** The fabric-reinforced rubber component of the air spring assembly.

**Lower End Closure.** Usually a metal cup-shaped component used to close off and seal the lower end of reversible sleeve type air springs. It is frequently molded to the flexible member. It generally has a blind nut which allows it to be secured to the piston and/or lower mounting surface by the use of a long bolt. Larger diameter end closures may have multiple studs allowing them to be bolted directly to the piston.

**Piston.** A metal or plastic component of the air spring assembly usually placed at the lower end of the flexible member and used to both support and provide a surface for the flexible member to roll on. It also provides a means for attaching the assembly to the mounting surface. Pistons with tailored contours may be used to obtain air spring characteristics to meet special performance requirements.

**Upper End Cap.** A plastic or metal component containing an air entrance and a means of fastening or positioning the air spring assembly to the adjacent mounting surface. The air entrance may be combined with a mounting stud.

#### **AIR SPRING TERMS**

**Assembly.** This includes the flexible member, which may include an end closure, upper bead plate, piston, or lower bead plate with an internal bumper. See illustration on page 11.

**Assembly Volume.** The internal working air volume, exclusive of any external working volume.

**Bumper Volume.** The space taken up inside the air spring assembly by the bumper. See Bumper Volume Chart on page 36.



**Compression Stroke (Jounce).** The reduction in height from the normal design height of the spring as it cycles in dynamic operation.

**Curb Load.** The normal minimum static load the air spring is expected to support. It is a zero payload condition, but includes that portion of the unloaded vehicle that is supported by the axle. It is this axle load divided by the number of air springs working with the axle and adjusted according to any lever arm ratio incorporated in the suspension.

**Design Load.** This is the normal maximum static load the air spring suspension is expected to support. It is the rated axle load divided by the number of air springs working with the axle and adjusted according to any suspension lever arm ratio incorporated.

**Design Height.** The overall height of the air spring as selected from the characteristics chart design position range. The air spring selected should provide for adequate jounce and rebound travel for the proposed suspension. The design height would be the starting position for calculating the spring and suspension dynamic characteristics.

**Dynamic Force.** The instantaneous supporting force developed by the air spring during vehicle motion. It is this constantly changing force that creates the spring rate, suspension rate, and in combination with the normal vehicle load on the spring, creates the suspension system's natural frequency.

**Effective Area.** The actual working area perpendicular to the output force of the spring. It is not the diameter of the spring. This working area, when multiplied by the gauge pressure in the spring, produces the correct output force. Conversely, dividing the measured output force of the spring by the measured internal gauge pressure obtains the correct effective area. In many cases, this is the only practical way to obtain it.

**Extension Stroke (Rebound).** The increase in height from the normal design height of the spring as it cycles in dynamic operation.

**Reservoir Volume.** Any working air volume located externally from the air spring assembly, but functioning with the spring.



## **SUSPENSION RELATED TERMS**

**Height Sensor.** An electronic device that senses the position of a suspension or other mechanical device. The output signal from this device is sent to a control circuit which then exhausts or adds air to the air spring through a solenoid valve.

**Leveling Valve.** A pneumatic valve that senses the distance between the vehicle frame and the axle via a mechanical linkage which adds or exhausts air pressure to maintain a constant vehicle height.

**Sprung Mass Natural Frequency.** The speed of vertical oscillations of the suspended vehicle sprung mass. Can be expressed in cycles per minute (cpm) or cycles per second (hertz).

**Sprung Mass (Weight).** That part of the vehicle structure and cargo that is supported by the suspension.

**Unsprung Mass.** That part of the suspension that is not supported by the spring (e.g., trailing arm, axle & wheels, air spring, etc.).

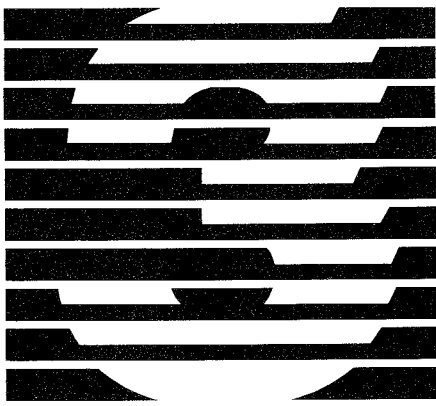

## TYPES OF AIR SPRINGS

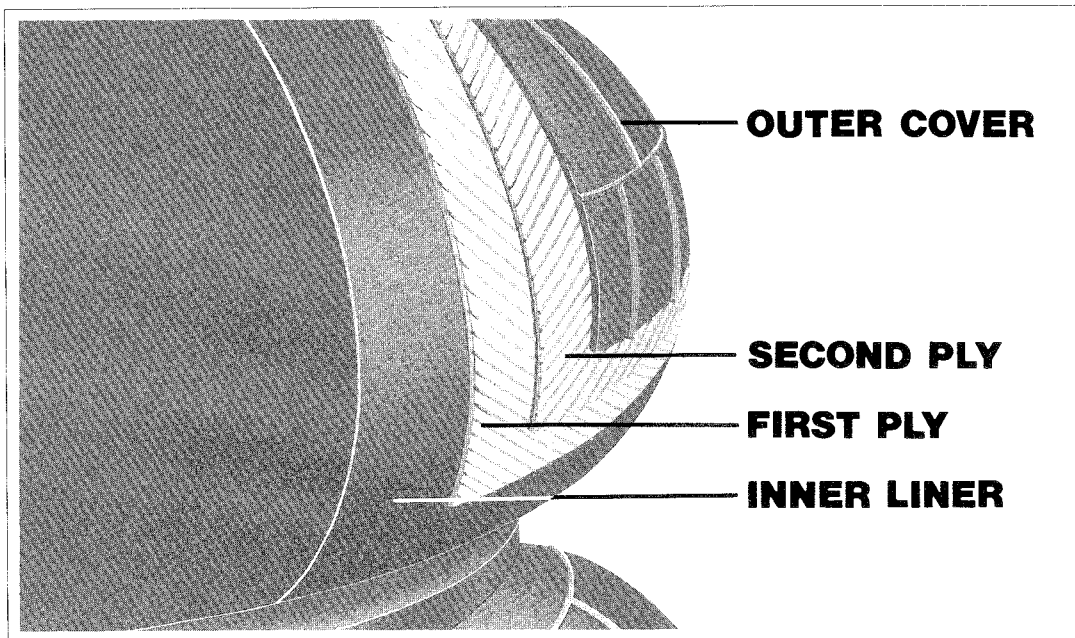

### FLEXIBLE MEMBER CONSTRUCTION

An air spring is a carefully designed rubber and fabric flexible member which contains a column of compressed air. The flexible member itself does not provide force or support load; these functions are performed by the column of air.

Firestone air springs are highly engineered elastomeric flexible members with specifically designed metal end closures. The standard two-ply version is made up of four layers:

- **Inner Liner.** An inner liner of calendered rubber.
- **First Ply.** One ply of fabric-reinforced rubber with the cords at a specific bias angle.
- **Second Ply.** A second ply of fabric-reinforced rubber with the same bias angle laid opposite that of the first ply.
- **Outer Cover.** An outer cover of calendered rubber.

Although the two-ply air spring is standard, many of our air springs are also available in four-ply rated construction for use at higher pressures.

Each air spring's flexible member is identified by a style number, which is molded in during the curing (vulcanization) process. Examples would be 16, 22, 313, 1T15M-6, etc. This identifies *only* the rubber/fabric flexible member . . . not the complete assembly.

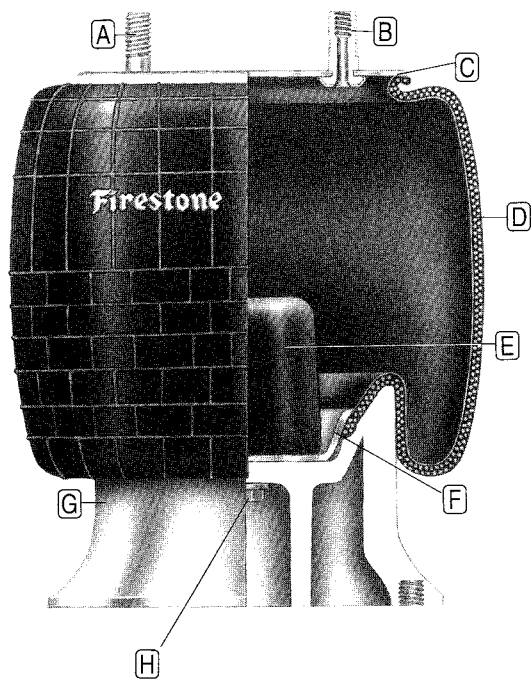

### REVERSIBLE SLEEVE STYLE AIR SPRING WITH CRIMPED BEAD PLATE

- A Stud.** Mounting stud. Usually 1/2"-13 UNC.

---

- B Combination Stud.** Combination 3/4"-16 UNF mounting stud with 1/4" NPT internal air entrance.

---

- C Bead Plate.** 9 gauge (.149") carbon steel, plated for corrosion resistance. Permanently crimped to the flexible member to form an airtight assembly which allows for leak testing before the unit leaves the factory.

---

- D Flexible Member.** Wall gauge is approximately .25 inches. See page 9 for detailed information.

---

- E Bumper (Optional).** An internal device to prevent damage to the air spring during times when no air is in the system.

---

**F** **End Closure.** This is made of steel and is permanently molded to the flexible member (except for 1T19 series air springs).

---

**G** **Piston.** May be made of aluminum, steel, or engineered composites. The threaded holes in the piston are used to secure the assembly to the mounting surface.

---

**H** **Piston Bolt.** Attaches the piston to the flexible member end closure. For mounting, a long bolt may be used coming up through the mounting surface and attaching to the end closure. Or, a short bolt may be used to attach the piston to the end closure.

**NOTE:** There are several different mounting options available for most air springs. Therefore, always specify both the style number and the complete Assembly Order Number (AON). For example, 1T15M-6, Assembly Order Number W01-358-9082. Both numbers are published on the Product Data Sheets for individual air springs.

#### **SERVICE ASSEMBLY**

On Firestone's reversible sleeve style Airide® air springs, the flexible member, with cured-in end closure and bead plate, is a separate sealed unit. This unit is called a *Service Assembly*, and may be purchased without the piston as an economical replacement for existing air springs in truck and trailer suspensions.

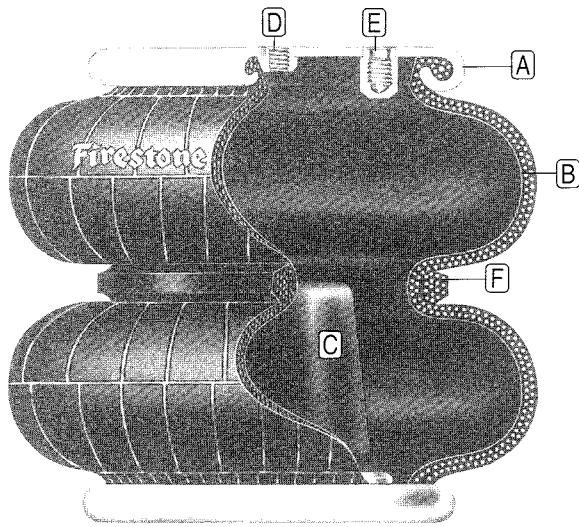

### CONVOLUTED STYLE AIR SPRING WITH CRIMPED BEAD PLATE

**A** **Bead Plate.** 9 gauge (.149") carbon steel. Plated for corrosion resistance. Permanently crimped to the flexible member to form an airtight assembly which allows for leak testing before the unit leaves the factory.

**B** **Flexible Member.** Wall gauge is approximately .25 inches. See page 9 for detailed information.

**C** **Bumper (Optional).** An internal device to prevent damage to the air spring during times when no air is in the system.

**D** **Flush Air Inlet.** 1/4" NPT is standard. 3/4" NPT is also available for most parts.

---

**E** **Blind Nut.** 3/8" -16 UNC thread x 5/8" deep (two or four per plate, depending upon the part size). Used for mounting the part.

---

**F** **Girdle Hoop.** A solid steel ring or stranded wire ring cured to the flexible member between the convolutions.

**NOTE:** There are several different mounting options available for most air springs. Therefore, always specify both the style number and the complete Assembly Order Number (AON). For example, Style #22, Assembly Order Number W01-358-7410. Both numbers are published on the Product Data Sheets for individual air springs.

### CONVOLUTED AIR SPRINGS - ROLLED PLATE ASSEMBLIES

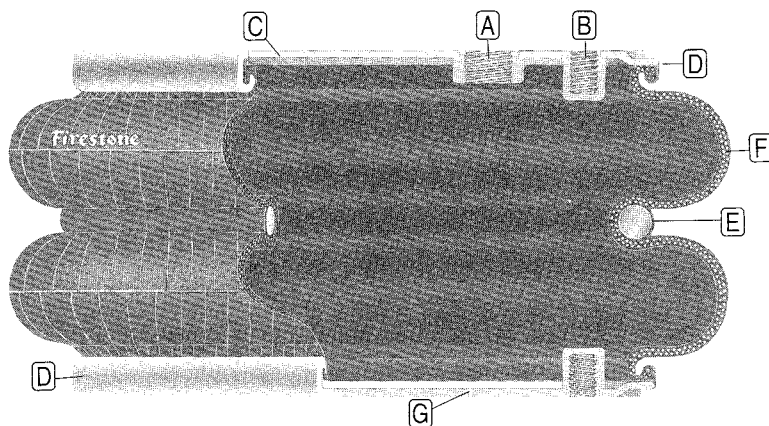

The larger convoluted parts are available with bead rings or permanently attached plates called, "rolled plates." Rolled plate assemblies may offer an advantage over the bead ring parts because installation is much easier (they attach the same way as the bead plate parts).

When installing the rolled plate parts, a backup plate as large in diameter as the bead plate must be used. This plate should be a minimum of 1/2" thick.

The blind nut and air entrance locations of rolled plate assemblies are available from Firestone.

**A** Air Inlet. 3/4" NPT is standard.

**B** Blind Nut. 1/2"-13 UNC thread x 3/4" deep is standard.

**C** Upper Bead Plate. 6-gauge (.194") carbon steel, plated for corrosion resistance. Permanently attached to the flexible member with a clamp ring (D) to form an airtight assembly. Allows for leak testing before the assembly leaves the factory.



---

**D Clamp Ring.** This ring is crimped to the bead plate to permanently attach it to the flexible member. It is also plated for rust protection.

---

**E Girdle Hoop.** Solid steel type cured to the flexible member between the convolutions

---

**F Flexible Member.** Wall gauge is approximately .25 inches (see page 9 for construction).

---

**G Lower Bead Plate.** Usually the same as the upper bead plate, except without the air inlet.

**CONVOLUTED AIR SPRINGS -  
BEAD RING ASSEMBLIES**

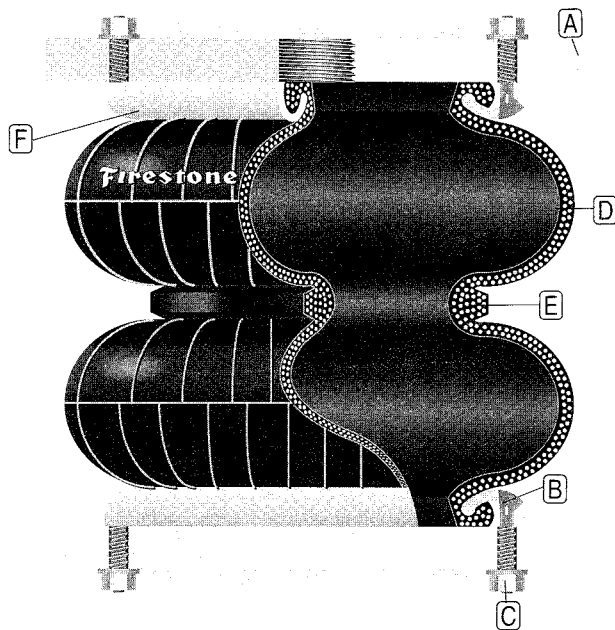

**A Mounting Plate.** Not included. See page 21 for material, machining recommendations and installation instructions.

**B Bead Ring Bolt.** May be one of four varieties included with air spring assemblies. See chart on page 21.

---

**C Nuts & Lock Washers.** Included with air spring assembly.

---

**D Flexible Member.** Wall gauge is approximately .25 inches.

---

**E Girdle Hoop.** Wire wound type shown, molded into the flexible member.

---

**F Bead Ring.** Steel countersunk type shown. May also be of a second stamped steel variety or made of aluminum (see page 21).

#### **SERVICE ASSEMBLY**

The flexible member is available separately as a replacement on convoluted bead ring assemblies.

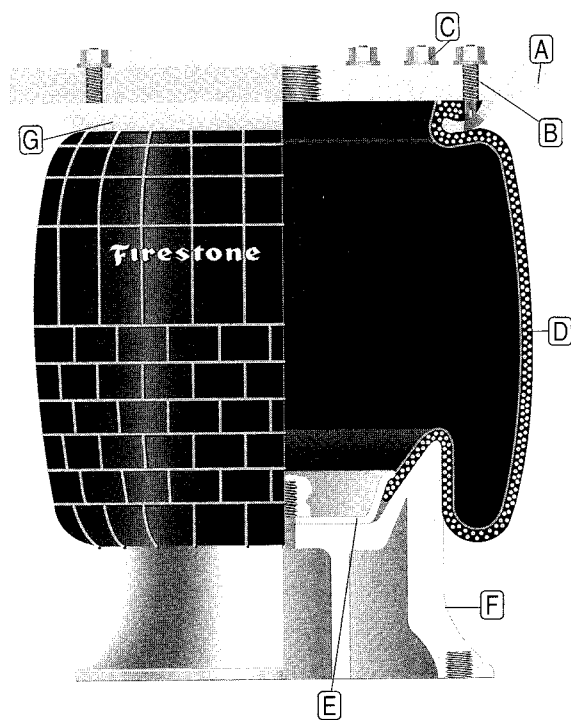

### REVERSIBLE SLEEVE AIR SPRINGS - BEAD RING ASSEMBLIES

- A** **Mounting Plate.** Not included. See page 21 for material, machining recommendations and installation instructions.

---

- B** **Bead Ring Bolt.** May be one of four varieties included with the air spring assembly (see chart on page 21).

---

- C** **Nuts & Lock Washers.** Included with air spring assembly.

---

- D** **Flexible Member.** Wall gauge is approximately .25 inches.

---

- E** **End Closure.** This is made of steel and is permanently molded into the flexible member (except for the 1T19 style air spring).

---

**F** **Piston.** May be made of aluminum, steel, or engineered composites. The threaded holes in the piston are used to secure the assembly to the mounting surface.

---

**G** **Bead Ring.** Steel countersunk type shown. May also be of a second stamped steel variety or made of aluminum. (See page 21).

#### **SERVICE ASSEMBLY**

The flexible member with cured-in end closure is available separately as a replacement.

## FOUR TYPES OF BEAD RINGS

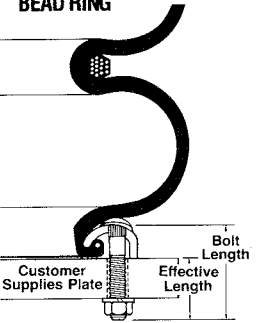
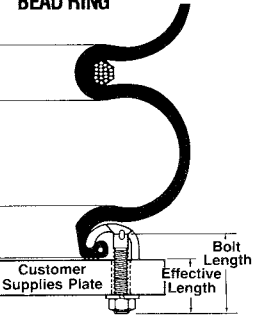
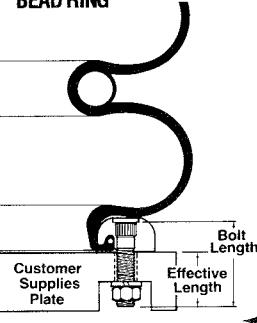
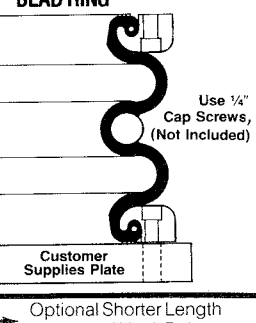
 <p><b>STEEL BUTTON HEAD BEAD RING</b></p>	 <p><b>STEEL COUNTER SUNK BEAD RING</b></p>	 <p><b>ALUMINUM RIBBED NECK BEAD RING</b></p>	 <p><b>ALUMINUM ALLEN HEAD BEAD RING</b></p> <p>Use 1/4" Cap Screws, (Not Included)</p>
<p>Standard Bolt Length (in) 1 7/8</p>	<p>Standard Bolt Length (in) 1 7/8</p>	<p>Standard Bolt Length (in) 1 7/8</p>	<p>Optional Bolt Length (in) (1 1/4)</p>
<p>Standard Effective Length (in) 1.28</p>	<p>Standard Effective Length (in) 1.22</p>	<p>Standard Effective Length (in) 1.28</p>	<p>Optional Effective Length (in) (.66)</p>
<p>Standard Order Number (bolt only) W01-358-3607</p>	<p>Standard Order Number (bolt only) W01-358-3625</p>	<p>Standard Order Number (bolt only) W01-358-3620</p>	<p>Optional Order Number (bolt only) (W01-358-3618)</p>
<p>Thread 3/16-24UNF</p>	<p>Thread 3/16-24UNF</p>	<p>Thread 3/8-24UNF</p>	<p>Thread 3/8-24 UNF</p>
<p>Tightening Torque (ft-lb) 17 to 22</p>	<p>Tightening Torque (ft-lb) 17 to 22</p>	<p>Tightening Torque (ft-lb) 28 to 32</p>	<p>Tightening Torque (ft-lb) 28 to 32</p>

## INSTALLING AIR SPRINGS WITH BEAD RINGS

When using bead rings, you will need to fabricate your own mounting plates. Hot or cold rolled steel provides satisfactory mounting surfaces with finishes of 250 micro inches, if machined in a circular fashion, or 32 micro inches when ground (side-to-side). The thickness of

mounting plates depends upon the application. The plates must be strong enough and backed by structural members to prevent bowing of the plates when subjected to the forces or loads involved. The flexible member provides its own seal, so "O" rings or other sealants are not required.

## INSTALLATION

Follow this technique for assembling a bead ring style flexible member to the mounting plate:

**1**

Insert the bolts into the bead ring, which has already been attached to the flexible member.

**2**

Slip all of the bolts, which protrude through the bead ring, into the mating holes of the mounting plate and attach the lock washers and nuts. Finger tighten all nuts to produce a uniform gap between the bead ring and mounting plate all the way around. The bolts will be pulled into place by the action of tightening the nuts. When using *aluminum* bead rings, it may be necessary to lightly tap the ribbed neck bolts with a small hammer to engage the splined portion into the bead ring.

**3**

Make certain that the flexible member bead is properly seated under the bead ring. *Please note that uniform successive tightening of the nuts is important to seat the rubber bead properly to the mounting plate around its full circumference.*

**4**

Tighten all nuts one turn each, moving around the circle until continuous contact is made between the bead ring and mounting plate.

**5**

Torque all nuts to the torque specifications shown in the chart on the previous page, going at least two complete turns around the bolt circle.

**NOTE:** Consult Firestone for proper selection of bead ring type.

# HOW TO USE THE PRODUCT DATA SHEETS

## INTRODUCTION

This section is a guide to using the Product Data Sheets which Firestone Industrial Products Company publishes for Airide® air springs.

These sheets delineate the mounting configuration, physical limitations and technical characteristics of the air spring. With this information, the suspension designer can accurately calculate the overall performance of his air suspension system.

The Product Data Sheets can also serve as a guide for selecting a particular air spring for a new suspension system.

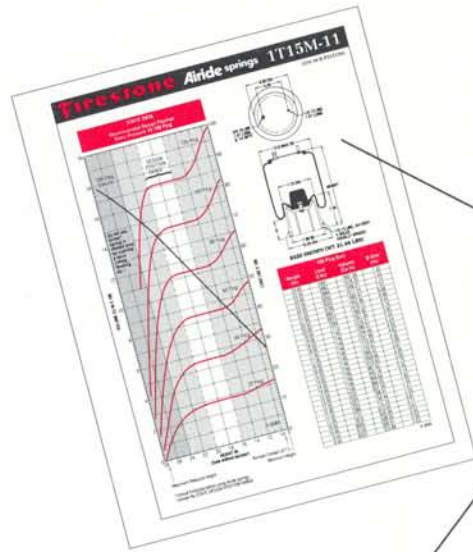

## AIR SPRING DRAWINGS

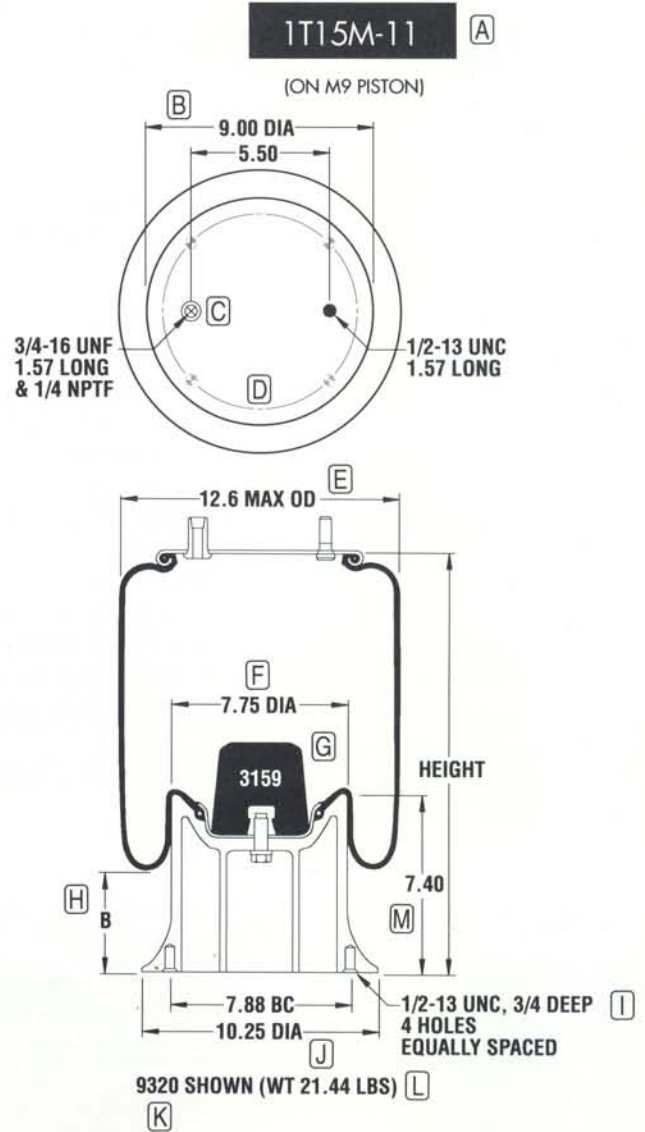



---

**A** The part description is shown in the upper right hand corner. The standard piston is used unless noted below the part description.

---

**B** Bead plate diameter.

---

**C** Bead plate mounting arrangement and air inlet location and size.

---

**D** Alignment: the relationship of the bead plate mounting to the piston mounting.

---

**E** Maximum rubber part diameter at 100 psig and minimum height.

---

**F** Piston body diameter.

---

**G** Bumper and reference number.

---

**H** "B" dimension. The distance from the mounting surface to the rubber loop at 100 psig.

---

**I** Mounting arrangement of the piston's threaded holes or stud(s).

---

**J** Piston base diameter.

---

**K** The last four digits of the Assembly Order Number, W01-358-9320.

---

**L** Approximate weight of the assembly.

---

**M** Piston height.

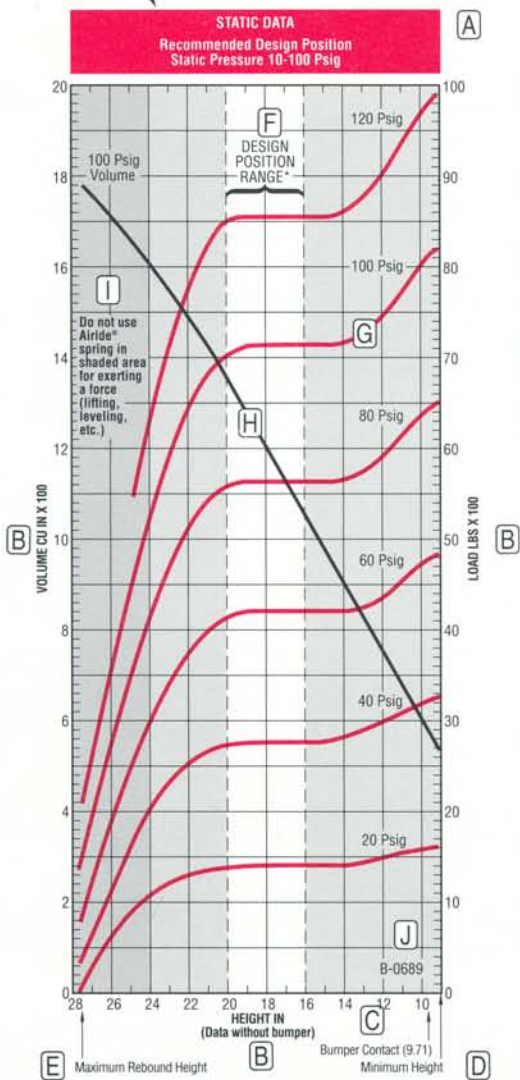
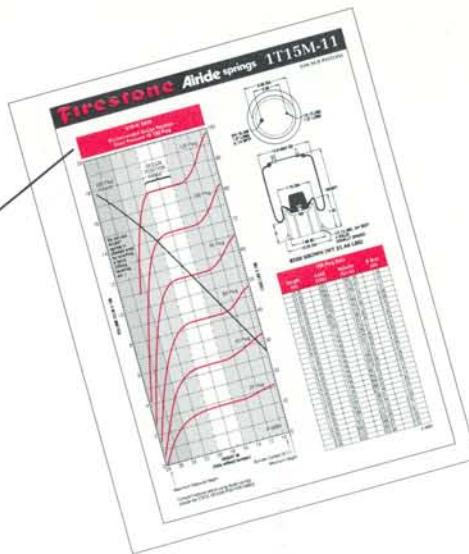

## STATIC DATA CHART

This chart is referred to as the *Static Load Deflection Curve* for an air spring. The following parameters are displayed:

- A** Recommended Design Position Static Pressure. The recommended static operating pressure range is shown at the top of the chart. This is 10 to 100 psig for most air springs. The minimum pressure is required to prevent internal damage to the air spring.
- B** The Load is given on the right-hand axis vs. the air spring Height along the bottom axis. The internal Volume is also given along the left hand axis vs. the Height.
- C** The Bumper Contact shows the compressed height of the air spring when the bead plate comes in contact with the internal bumper as shown on the air spring drawing.
- D** The Minimum Height shows the lowest compressed position of the air spring before internal contact. In many instances, an external positive stop may be required to prevent internal damage to the air spring.

---

**E** The **Maximum Rebound Height** is the maximum extended position of the air spring before the flexible member is put in tension. Some means of preventing the suspension extending the air spring past this height must be provided to prevent damage to the air spring. Shock absorbers are typically used, however chains, straps, and positive stops may also be used.

---

**F** The **Design Position Range** shows the recommended operating range of static heights. This range is 16 to 20 inches for the 1T15M-11, as shown on the chart. Use outside this range may be possible, however, Firestone should be consulted.

---

**G** The **Constant Pressure Curve** is the Load trace obtained as the part is compressed from the maximum height to the minimum height while maintaining a regulated constant pressure in the part. A series of constant pressure curves, 20 psig through 120 psig are shown at 20 psi increments. The 120 psig curve is shown for reference only, as most parts are limited to static design pressure of 100 psig.

---

**H** The **Volume Curve** is a plot of the data points obtained by measuring the volume of exhausted liquid as the part is compressed from maximum to minimum height while maintaining a regulated pressure of 100 psig in the air spring. (This is the volume without a bumper).

---

**I** The **Shaded Area** (24" to 28") on the left side of the chart is a range of heights in which the air spring is not normally used except during unloading as the axle goes in rebound. Do not use in this range of heights for applying a force.

---

**J** The number, B-0689, is the **Test Request Reference Number**.

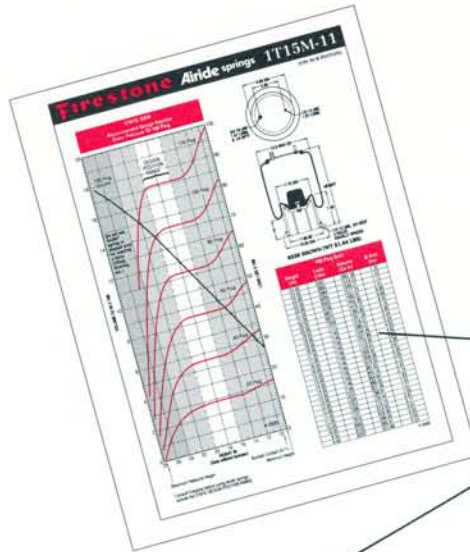

### 100 PSIG DATA TABLE

100 Psig Data			
Height (In)	Load (Lbs)	Volume (Cu In)	B-Dim (In)
24.00	5301.	1607.58	7.32
23.50	5662.	1578.33	7.22
23.00	5984.	1548.21	7.12
22.50	6265.	1517.24	7.01
22.00	6503.	1485.47	6.68
21.50	6700.	1452.95	6.68
21.00	6857.	1419.72	6.45
20.50	6975.	1385.82	6.16
20.00	7059.	1351.30	5.85
19.50	7113.	1316.21	5.54
19.00	7140.	1280.57	5.24
18.50	7146.	1244.46	4.93
18.00	7146.	1207.89	4.62
17.50	7146.	1170.92	4.30
17.00	7146.	1133.61	3.99
16.50	7146.	1095.97	3.67
16.00	7146.	1058.06	3.36
15.50	7146.	1019.93	3.05
15.00	7146.	981.62	2.75
14.50	7146.	943.18	2.42
14.00	7146.	904.64	2.14
13.50	7146.	866.05	1.83
13.00	7233.	827.46	1.52
12.50	7334.	788.91	1.27
12.00	7453.	750.44	1.03
11.50	7586.	712.10	0.87
11.00	7727.	673.93	0.71
10.50	7870.	635.99	0.61
10.00	8005.	598.30	0.55
9.50	8120.	560.91	0.50
9.00	8202.	523.88	0.53

This is a table of static data on the 100 psig constant pressure curve with loads, volumes and "B" dimensions shown.

The Static Data Table contains the following information:

- Height at each 1/2-inch increment.
- Load at each 1/2-inch increment.
- Volume at each 1/2-inch increment (without bumper).
- "B" dimension (the distance from the piston base mounting surface to the bottom of the rubber loop) at each 1/2-inch increment.

*All data is calculated without a bumper*

B-0689

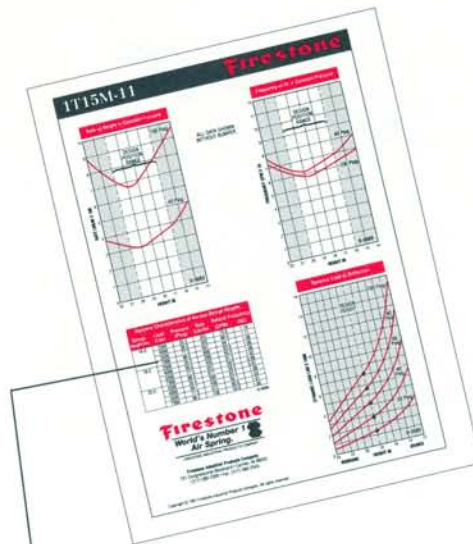

### DYNAMIC CHARACTERISTICS TABLE

The Dynamic Characteristics Table consists of the following calculated characteristics:

- Data for three design heights within the design position range: minimum, mid-range and maximum.
- Four loads at each design height.
- Pressure, Rate, and Frequency for each design height and load condition.

Dynamic Characteristics at Various Design Heights					
Design Height (In)	Load (Lbs)	Pressure (Psig)	Rate (Lbs/In)	Natural Frequency	
				(CPM)	(HZ)
16.0	2500	35.0	353.	70.6	1.18
	4000	56.0	502.	66.6	1.11
	5500	77.0	651.	64.7	1.08
	7000	98.0	800.	63.6	1.06
18.0	2500	35.0	299.	65.0	1.08
	4000	56.0	425.	61.3	1.02
	5500	77.0	551.	59.5	0.99
	7000	98.0	677.	58.5	0.97
20.0	2500	35.4	300.	65.2	1.09
	4000	56.7	436.	62.1	1.03
	5500	77.9	572.	60.6	1.01
	7000	99.2	708.	59.8	1.00

B-0689

*All data is calculated without a bumper*



### RATE VS HEIGHT CHART

This chart shows the variation in **Rate vs. Height** at constant pressures of 40 and 100 psig. The Design Position Range is also shown.

You may use this chart as a guide to determine the range of rates obtainable using a particular air spring.

Rates for a specific design height and load or pressure can also be calculated.

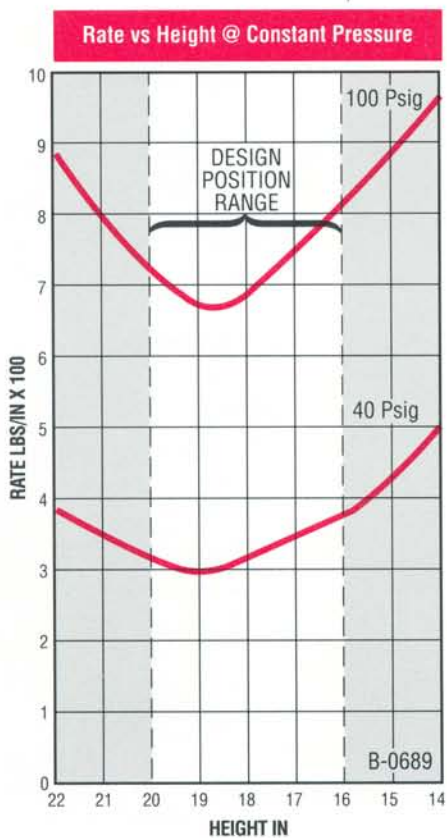

*All data is calculated without a bumper*

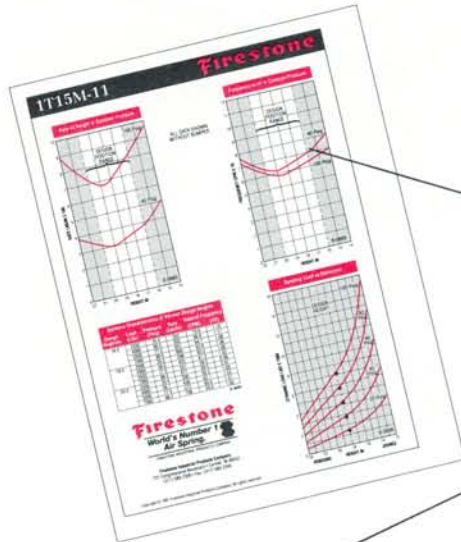

### FREQUENCY VS HEIGHT CHART

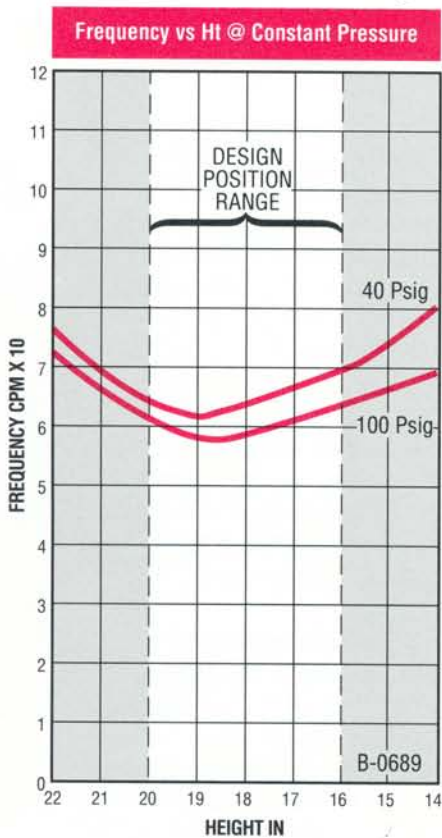

This chart shows the variation in **Frequency vs. Height** at constant pressures of 40 and 100 psig. The Design Position Range is also shown.

This is the chart you use to determine the range of frequencies obtainable using a particular air spring.

Frequencies for specific design heights and load or pressure can also be calculated.

*All data is calculated without a bumper*

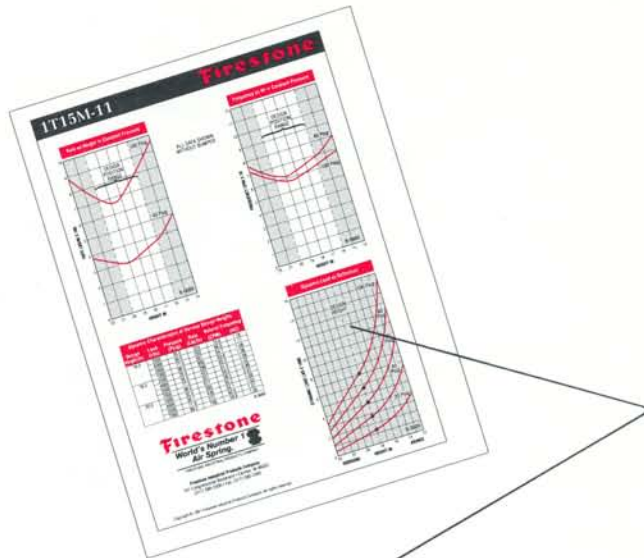

### DYNAMIC LOAD VS DEFLECTION CHART

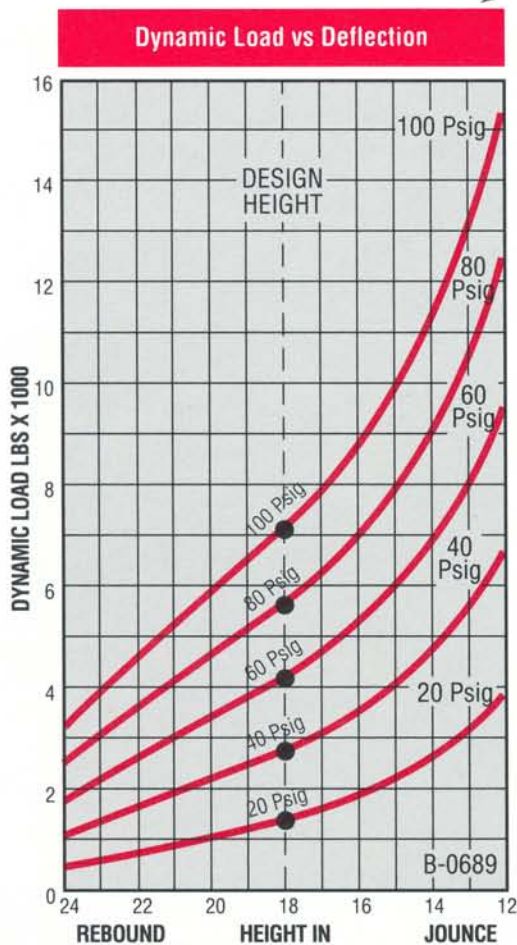

This chart shows the variation in **Dynamic Load vs. Deflection** for the 1T15M-11.

The curves are obtained by extending (rebound) or compressing (jounce) the air spring with captured air.

The *starting* point for each curve is at a design height of 18 inches, which is the mid-design position, and *starting* pressures of 20, 40, 60, 80 and 100 psig.

As you can see on the DYNAMIC LOAD axis, the load is approximately 7,000 lb at the design height of 18 inches and pressure of 100 psig.

When the air spring is compressed three inches to a 15-inch height, the load increases to approximately 9,800 lb, with a corresponding increase in pressure to 138 psig.

When the air spring is extended three inches to a 21-inch height, the load is reduced to 5,200 lb, with a corresponding reduction in pressure to 77 psig.

The method used in calculating points on a dynamic load vs. deflection curve is shown in Section 7 under Calculating Dynamic Load, on page 51. In addition, these calculations can be performed using a personal computer, as demonstrated in Section 8, on pages 67-70.







## APPLICATION CONSIDERATIONS

Obtaining the maximum performance and life from Airide® air springs requires proper application.

### **AIR SPRING CHOICE CONSIDERATIONS**

The air spring design height should be kept within the recommended range to get optimum performance and durability. Select a spring that carries the suspension rated load in the range of 80-90 psig. This gives you an air spring that has the optimum characteristics for your application (i.e., natural frequency, size, cost, etc.). The compressed height of the air spring in the suspension must not be less than the minimum height of the air spring chosen, as shown on the Product Data Sheet.

Conversely, the extended height of the air spring in the suspension must not be greater than the maximum extended height of the air spring chosen (refer to the Product Data Sheet).

### **INSTALLATION CONCERNS (CONVOLUTED AIR SPRINGS)**

To achieve the maximum lifting force, and produce a minimum of horizontal forces, convoluted air springs should be positioned at the normal design height

with the centers of both bead plates aligned. The bead plates can be angled so that a good relationship between compression and extension travel can be achieved with appropriate bumper contact.

The maximum extended height should never be exceeded. Under normal conditions, the included angle between the bead plates should not be greater than 20°, however with Firestone's approval, angles of up to 30° may be acceptable on some models.

### **INSTALLATION CONCERNS (REVERSIBLE SLEEVE AIR SPRINGS)**

Reversible sleeve air springs incorporating internal bumpers should have the bead plate and piston parallel within 3 to 5° at bumper contact height. Normally, the piston is angled at the design position so that a good relationship between compressed and extended travel can be achieved.

Reversible sleeve air springs which do not have an internal bumper may have the piston angled to allow full compression stroke without the flexible member being pinched between the piston and the bead plate.

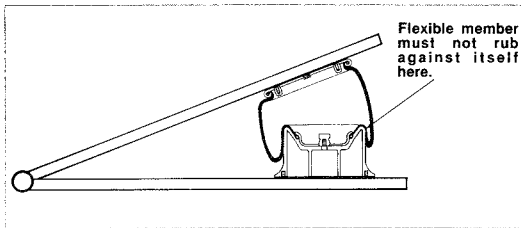

Reversible sleeve type air springs may stroke through an arc, but care must be taken to prevent the flexible member from rubbing internally against itself where it rolls over the piston.

Plastic pistons should normally be fully supported over the entire base surface. Exceptions should be reviewed by Firestone.

Metal pistons used with 1T15 size or smaller assemblies may be mounted on a flat beam surface at least three inches wide which extends the full diameter of the piston base.

Bead plates should be supported by a back-up plate the size of the bead plate. Under certain circumstances, the bead plate may be supported by a minimum three-inch wide beam. These mountings should also be reviewed by Firestone.

If a single long fastening bolt is used to clamp the air spring end closure and the piston to the trailing arm, it should be grade 5 or above, and tightened according to the appropriate value shown in the chart on page 35. If the piston is tipped more than 5 degrees, some means should be provided to locate the piston.

### FASTENER TIGHTENING SPECIFICATIONS

Description	Size	Torque (lb-ft)
• Bead ring nuts on bolts	5/16-24	17-22
• Bead ring bolts and nuts	3/8-24	28-32
• Bolts in blind nuts in bead plates	3/8-16	15-20
• End of adapter studs in blind nut	3/8-16	15-20
• Nut on end of adapter studs	1/2-13	25-30
• Studs on bead plates or blind nuts	1/2-13 or 1/2-20	25-30
• Bolt to attach piston base to lower mounting surface	1/2-13	25-30
• Nut on air entrance stud	3/4-16	40-45
• NPT air supply fitting	1/4 & up	17-22
• Nut on end closure lower mounting	3/4-10	45-50

### OPERATIONAL CAUTIONS

Air spring failure can be caused by a variety of situations, including internal or external rubbing, excessive heat and overextension. For further details, refer to Section 9, *Warranty Considerations*.

Bead plates are normally fully supported, however, mounting the bead plate directly to the frame rail, or other mounting surface with less than full support, may be possible.

### TEMPERATURE RANGE

The normal ambient operating temperature range for standard vehicular air springs is -65°F to +135°F.

### BUMPERS

In general, bumpers are used to support the vehicle weight to prevent damage to the flexible member during times when no air is in the system. They are also used as stops when the axle is raised by a lift unit. In applications that require frequent bumper contact, consult Firestone.

---

**BUMPER VOLUMES**

---

<b>Bumper Number</b>	<b>Volume Cu. In.</b>
3073	48.5
3136	8.8
3147	28.5
3155	70.3
3157	93.0
3159	41.0
3162	40.4
3209	65.3
3285	43.4
3294	33.9
3350	19.7
3386	9.4
3404	34.6
3604	37.7
3691	11.3
3777	31.0
4457	48.0
4518	22.1
4519	28.2
4964	1.6
7725	32.2

**CAUTION:** Contact Firestone for specific bumper applications

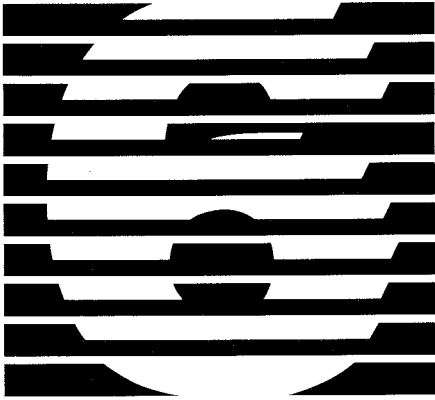

## **BASIC PRINCIPLES**

### **INTRODUCTION**

The fundamental concept of an air spring is a mass of air under pressure in a vessel arranged so that the pressure exerts a force. The amount of static force developed by the air spring is dependent on the internal pressure and the size and configuration of the vessel. The vessel is defined in this manual as the Airide<sup>®</sup> spring by Firestone or air spring.

Dynamic force is the result of internal pressure changes and air spring effective area changes as height decreases (compresses) or increases (extends).

The amount of pressure change for a stroke depends on volume change compared to total volume at equilibrium position. For the convoluted type, effective area change for a stroke depends on where in the total travel range the motion takes place. For the reversible sleeve type, the shape of the piston, size of the piston related to the flexible member diameter, and cord angle built into the flexible member all have an influence on effective area.

The effective area can be arrived at by taking the longitudinal static force developed at a specified assembly height and dividing this force by the internal pressure (psig) existing in the air spring at that height. This method is used to develop the static effective areas used in dynamic rate and frequency calculations.

## EFFECTIVE AREA

Effective area is the load carrying area of the air spring. Its diameter is determined by the distance between the centers of the radius of curvature of the air spring loop. The loop always approximates a circle because the internal air pressure is acting uniformly in all directions, so that only the area inside the centers is vertically effective. For a convoluted air spring, the effective area increases in compression and decreases on extension. For a reversible sleeve air spring, the effective area is constant while operating on the straight side of the piston, increases when working on the flare of the piston in compression, and decreases when the rubber part lifts off the piston in extension.

When a vehicle having air springs in its suspension is at rest, and then load is added or removed, the height control valve operates to add or remove sufficient air in the air spring to maintain the set air spring overall height. This then increases or decreases the pressure in the air spring the amount needed to provide the required lifting force to match the current downward force created by the new load condition, and equilibrium is again reached.

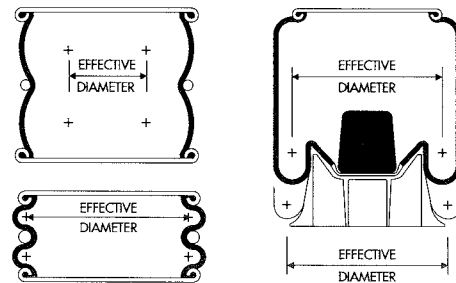

Convoluted  
Air Spring  
Change In  
Effective Diameter

Reversible Sleeve  
Air Spring  
Change In  
Effective Diameter

$$\text{Effective area} = \frac{\text{Load}}{\text{Pressure}}$$

$$\text{Load (supporting force)} = \text{Pressure} \times \text{Area}$$

### **SPECIAL CHANGES OF STATE FOR PERFECT GASES**

*Non-flow process, specific heats assumed constant. Subscripts 1 and 2 refer to the initial and final states, respectively.*

P = Absolute Pressure  
T = Absolute Temperature  
V = Total Volume

---

#### **1** Constant Volume (Isochoric)

$$\frac{P_2}{P_1} = \frac{T_2}{T_1}$$

This is an unattainable process due to the nature of the flexible member, however, at static conditions, the change in pressure may be calculated for a change in temperature.

---

#### **2** Constant Pressure (Isobaric)

$$\frac{V_2}{V_1} = \frac{T_2}{T_1}$$

Dynamically, the only way to maintain constant pressure is in combination with infinite volume and is generally not useful.

---

#### **3** Constant Temperature (Isothermal)

$$\frac{P_2}{P_1} = \frac{V_1}{V_2}$$

This requires very slow movements not normally applicable to air spring operation.

---

#### **4** Reversible Adiabatic (Isentropic)

$$P_1 V_1^k = P_2 V_2^k$$

And:

$$\frac{T_2}{T_1} = \left( \frac{V_1}{V_2} \right)^{k-1} = \left( \frac{P_2}{P_1} \right)^{(k-1)/k}$$

This is defined as a process with no heat transferred to or from the working fluid. This is a theoretical process not attainable with pneumatic springs, however, for rapid deflections, it is closely approached.  $k=1.404$  for air.



**5** Polytropic

$$PV^n = \text{Constant}$$

This process usually represents actual expansion and compression curves for pressures up to a few hundred pounds. By giving "n" different values and assuming specific heats constant, the preceding changes may be made special cases of the polytropic change. Thus for:

- $n = 1$ ,  $PV = \text{Const.}$  (Isothermal)
- $n = k$ ,  $PV^k = \text{Const.}$  (Isentropic)
- $n = 0$ ,  $P = \text{Const.}$  (Constant Pressure)
- $n = \infty$ ,  $V = \text{Const.}$  (Constant Volume)

The principal formulas for *air compression* up to a few hundred pounds pressure where  $1 < n < k$  are:

**6**  $P_1 V_1^n = P_2 V_2^n$

and

$$\frac{T_2}{T_1} = \left( \frac{V_1}{V_2} \right)^{n-1} = \left( \frac{P_2}{P_1} \right)^{(n-1)/n}$$

During air spring dynamic operation, the pressure, volume and temperature change instantaneously. The air spring flexible member structure also changes depending upon the specific configuration. As a result, air springs operate in the range  $1 < n < k$ , however, a generally acceptable value for "n" is 1.38 for normal vehicle operation.

**Note:** Shadow boxes  are used to designate important formulas.

## DYNAMIC AIR SPRING RATE

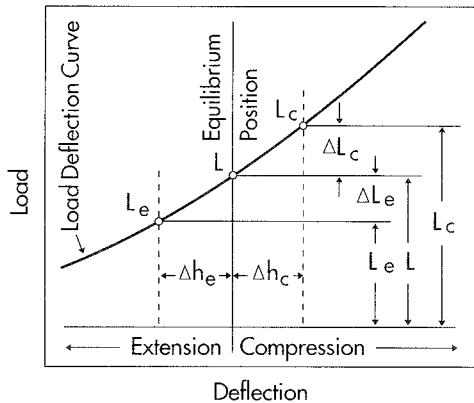

Rate is the slope of the tangent at the equilibrium position. For small increments of deflection, rate equals the load change per unit deflection.

*(The slope of the chord line through  $L_c$  and  $L_e$  is parallel to the tangent at  $L$  for small deflections.)*

$$\mathbf{1} \quad K = (L_c - L_e) / (\Delta h_c + \Delta h_e)$$

Where:

- $K$  = Rate (Load per unit deflection)
- $L_c$  = Load at compression travel
- $L_e$  = Load at extension travel
- $\Delta h_c$  = Height change, compression
- $\Delta h_e$  = Height change, extension

$$\mathbf{2} \quad L_c = P_{gc}(A_c)$$

$$L_e = P_{ge}(A_e)$$

Where:

- $P_{gc}$  = Gauge Pressure at  $L_c$
- $P_{ge}$  = Gauge Pressure at  $L_e$
- $A_c$  = Effective area at  $L_c$
- $A_e$  = Effective area at  $L_e$

substituting **2** in **1** and setting  $\Delta h_c = \Delta h_e = .5$  inch

$$\mathbf{3} \quad K = P_{gc}(A_c) - P_{ge}(A_e)$$

$$\mathbf{4} \quad P_{gc} = P_{ac} - 14.7$$

$$P_{ge} = P_{ae} - 14.7$$

Where:

- $P_{ac}$  = Absolute Pressure at  $L_c$
- $P_{ae}$  = Absolute Pressure at  $L_e$
- 14.7 = Atmospheric Pressure

**5** now using the polytropic gas law and  $n = 1.38$

$$P_{ac} = P_{a1} \left( \frac{V_1}{V_c} \right)^{1.38}$$

$$P_{ae} = P_{a1} \left( \frac{V_1}{V_e} \right)^{1.38}$$

Where:

$P_{a1}$  = Absolute pressure at  
equilibrium position

$V_1$  = Volume at  
equilibrium position

$V_c$  = Volume at  $L_c$

$V_e$  = Volume at  $L_e$

substituting **5** in **4**

---

$$\mathbf{6} \quad P_{gc} = P_{a1} \left( \frac{V_1}{V_c} \right)^{1.38} - 14.7$$

$$P_{ge} = P_{a1} \left( \frac{V_1}{V_e} \right)^{1.38} - 14.7$$

now substitute **6** in **3**

$$\mathbf{3} \quad K = P_{gc}(A_c) - P_{ge}(A_e)$$

---

$$\mathbf{7} \quad K = \left[ P_{a1} \left( \frac{V_1}{V_c} \right)^{1.38} - 14.7 \right] A_c - \left[ P_{a1} \left( \frac{V_1}{V_e} \right)^{1.38} - 14.7 \right] A_e$$

Then, grouping terms, this becomes the general rate formula for air springs.

---

$$\mathbf{8} \quad K = P_{a1} \left[ A_c \left( \frac{V_1}{V_c} \right)^{1.38} - A_e \left( \frac{V_1}{V_e} \right)^{1.38} \right] - 14.7(A_c - A_e)$$

### NATURAL FREQUENCY

Since the air spring has a variable rate and essentially a constant frequency, it is helpful to calculate the natural frequency when evaluating characteristics.

When considering a single-degree-of-freedom system (undamped), the classical definition of frequency is as follows:

**Note:** The period of free vibration (which is the reciprocal of frequency) is the same as the period of a mathematical pendulum, the length of which is equal to the static deflection of the spring under the action of load W.

$$f = \frac{\omega}{2\pi} \text{ and } \omega^2 = \frac{K}{m}$$

Where:

f = Frequency, cycles per second

$\omega$  = Circular frequency, radians per second

K = Rate, pounds per inch

m = Mass, pound seconds<sup>2</sup> per inch

Then:

$$f = \frac{\sqrt{\frac{K}{m}}}{2\pi} = \frac{1}{2\pi} \sqrt{\frac{K}{m}}$$

Also:

$$m = \frac{W}{g}$$

Where:

W = Weight, pounds

g = Acceleration of gravity, 386 inches per second<sup>2</sup>

Substituting:

$$f = \frac{1}{2\pi} \sqrt{\frac{Kg}{W}} = \frac{\sqrt{386}}{2\pi} \sqrt{\frac{K}{W}} \text{ cps}$$

$$f = \frac{60\sqrt{386}}{2\pi} \sqrt{\frac{K}{W}} \text{ cpm}$$

$$f = 187.61 \sqrt{\frac{K}{W}} \text{ cpm}$$

This is normally rounded to:

$$f = 188 \sqrt{\frac{K}{W}} \text{ cpm}$$

Where:

K = Rate

W = Weight (load)

Also since:

$$\frac{W}{K} = d_e \text{ (effective deflection)}$$

$$f = \frac{188}{\sqrt{d_e}} \text{ cpm}$$

Effective deflection ( $d_e$ ) has no physical significance, however, has mathematical meaning. It is defined as load divided by rate and is graphically explained below.

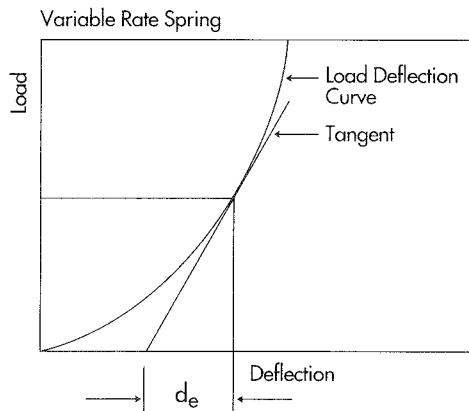

$$d_e = \frac{\text{Load}}{\text{Rate}}$$

$$\text{Load} = \text{Rate} \times d_e$$

**Note:** For a constant rate spring,  $d_e$  and the deflection from free height are equal.

### SPRING MASS SYSTEM WITH LEVER ARM

The rate and frequency at the wheel (axle) are the same as that of the spring only if the centerline of the spring is located on the centerline of the wheel. The following is a derivation of the rate and frequency relationship at the wheel

vs. the spring located fore or aft of the wheel. Note the distance to the spring is always 'A' whether located forward or aft of the axle.

Schematic representation of a trailing arm suspension:

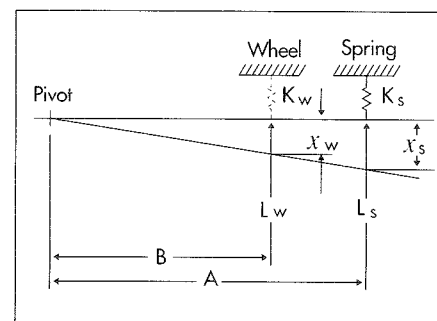

Where:

$$\text{Lever Arm Ratio} = \text{LAR}$$

$$\text{LAR} = \frac{\text{Distance to spring}}{\text{Distance to wheel}} = \frac{A}{B}$$

And:

$$K_s = \text{Rate at spring}$$

$$L_s = \text{Load at spring}$$

$$\chi_s = \text{Deflection at spring}$$

For an equivalent spring at the wheel:

$$K_w = \text{Rate at wheel}$$

$$L_w = \text{Load at wheel}$$

$$\chi_w = \text{Deflection at wheel}$$

### RATE RELATIONSHIP

Balancing moments about the pivot

---

**1**  $L_s A = L_w B$

$$L_s = L_w \left( \frac{B}{A} \right) = \frac{L_w}{\left( \frac{A}{B} \right)} = \frac{L_w}{LAR}$$

Also:

$$\chi_w = \chi_s \left( \frac{B}{A} \right)$$

Load = Rate  $\times$   $d_e$

---

**2**  $L_w = K_w \chi_w = K_w \left[ \chi_s \left( \frac{B}{A} \right) \right]$

Solving for  $K_w$

---

**3**  $K_w = \frac{L_w}{\chi_s} \left( \frac{A}{B} \right)$

---

**4**  $L_s = K_s \chi_s$

substituting **1** in **4**

$$L_w \left( \frac{B}{A} \right) = K_s \chi_s$$

Solving for  $L_w$

---

**5**  $L_w = K_s \chi_s \left( \frac{A}{B} \right)$

substituting **5** in **3**

$$K_w = \frac{K_s \chi_s \left( \frac{A}{B} \right) \left( \frac{A}{B} \right)}{\chi_s}$$

---

**6**  $K_w = K_s \left( \frac{A}{B} \right)^2 = K_s (LAR)^2$

So:

$\text{Rate at wheel} = \text{Rate at spring} \times (LAR)^2$

### FREQUENCY RELATIONSHIP

---

**7**  $f_s = 188 \sqrt{\frac{K_s}{L_s}} \text{ cpm}$

And:

---

**8**  $f_w = 188 \sqrt{\frac{K_w}{L_w}} \text{ cpm}$

from the natural frequency derivation where

$f_s$  = Frequency at spring

$f_w$  = Frequency at wheel

Also:

$L_s A = L_w B$  from **1**

Solving for  $L_s$

---

**9**  $L_s = L_w \left( \frac{B}{A} \right)$

substitute **9** in **7**

---

**10**  $f_s = 188 \sqrt{\frac{K_s}{L_w \left( \frac{B}{A} \right)}} = 188 \sqrt{\frac{K_s}{L_w} \left( \frac{A}{B} \right)}$

now using  $K_w = K_s \left( \frac{A}{B} \right)^2$  from **6**

and substitute in **8**

$$f_w = 188 \sqrt{\frac{K_s \left( \frac{A}{B} \right)^2}{L_w}} = 188 \sqrt{\frac{K_s}{L_w} \left( \frac{A}{B} \right)} \times \sqrt{\frac{A}{B}}$$

now substitute  $f_s$  from **10**

$$f_w = f_s \sqrt{\frac{A}{B}}$$

Or:

$$f_w = f_s (\text{LAR})^{1/2}$$

So:

$$\text{Frequency at wheel} = \text{Frequency at spring} \times (\text{LAR})^{1/2}$$

### **SUMMARY OF IMPORTANT FORMULAS FROM BASIC PRINCIPLES**

Polytropic Gas Law

$$P_1 V_1^n = P_2 V_2^n$$

Dynamic Air Spring Rate

$$K = P_{a1} \left[ A_c \left( \frac{V_1}{V_c} \right)^{1.38} - A_e \left( \frac{V_1}{V_e} \right)^{1.38} \right] - 14.7(A_c - A_e)$$

Natural Frequency

$$f_s = 188 \sqrt{\frac{K_s}{L_s}} = \frac{188}{\sqrt{d_e}} \text{ cpm}$$

Lever Arm Considerations

$$\text{LAR} = \frac{\text{Distance to spring}}{\text{Distance to wheel}} = \frac{A}{B}$$

$$\begin{aligned} \text{Rate at wheel} &= \text{Rate at spring} \times (\text{LAR})^2 \\ K_w &= K_s (\text{LAR})^2 \end{aligned}$$

$$\begin{aligned} \text{Frequency at wheel} &= \text{Frequency at spring} \times (\text{LAR})^{1/2} \\ f_w &= f_s (\text{LAR})^{1/2} \end{aligned}$$







## **SAMPLE CALCULATIONS: AIR SPRINGS & SUSPENSIONS**

### **CALCULATING DYNAMIC RATE AND FREQUENCY**

The dynamic rate of an air spring over a plus and minus ½ inch stroke is calculated using Formula 8 on page 42, substituting values as follows:

Where:

$$K = \text{Rate (lb/in)}$$

$$\begin{aligned} P_{a1} &= \text{Absolute pressure (psia) at} \\ &\text{design position} \\ &= \text{Gauge pressure (psig) at design} \\ &\text{position plus 14.7} = P_{g1} + 14.7 \end{aligned}$$

$$\begin{aligned} A_1 &= \text{Effective area (in}^2\text{) at design position} \\ &= \text{Load (lb)} \div \text{Pressure (lb/in}^2\text{)} \end{aligned}$$

$$\begin{aligned} A_c &= \text{Effective area (in}^2\text{) at } \frac{1}{2} \text{ inch} \\ &\text{below design position} \\ &= \text{Load (lb)} \div \text{Pressure (lb/in}^2\text{)} \end{aligned}$$

$$\begin{aligned} A_e &= \text{Effective area (in}^2\text{) at } \frac{1}{2} \text{ inch} \\ &\text{above design position} \\ &= \text{Load (lb)} \div \text{Pressure (lb/in}^2\text{)} \end{aligned}$$

$$V_1 = \text{Internal volume at design position (in}^3\text{)}$$

$$V_c = \text{Internal volume at } \frac{1}{2} \text{ inch below design position (in}^3\text{)}$$

$$V_e = \text{Internal volume at } \frac{1}{2} \text{ inch above design position (in}^3\text{)}$$

For example, find the air spring rate of the 1T15M-11, W01-358-9320 at an 18 inch design height and a load of 7000 pounds. See the Product Data Sheet for the necessary information.

The effective area on the 100 psig curve is calculated:

$$A_1 = \frac{\text{Load}}{\text{Pressure}} = \frac{7146}{100} = 71.46 \text{ in}^2$$

Also calculate  $A_c$  and  $A_e$ :

$$A_c = \frac{7146}{100} = 71.46 \text{ in}^2$$

$$A_e = \frac{7146}{100} = 71.46 \text{ in}^2$$

Then calculate the pressure at 7000 pounds:

$$P_{g1} = \frac{7000}{71.46} = 97.96 \text{ psig}$$

Then calculate the rate:

$$K = P_{a1} \left[ A_c \left( \frac{V_1}{V_c} \right)^{1.38} - A_e \left( \frac{V_1}{V_e} \right)^{1.38} \right] - 14.7(A_c - A_e)$$

$$K = (97.96 + 14.7) \left[ 71.46 \left( \frac{1207.89}{1170.92} \right)^{1.38} - 71.46 \left( \frac{1207.89}{1244.46} \right)^{1.38} \right] - 14.7(71.46 - 71.46)$$

$$K = 112.66 [74.59 - 68.58] - 0$$

$$K = 677 \text{ lb/in}$$

Now calculate the frequency:

$$f = 188 \sqrt{\frac{K}{W}} = 188 \sqrt{\frac{677}{7000}}$$

$$f = 58.5 \text{ cpm}$$

**Note:** These are the same values shown in the Dynamic Characteristics Chart on the Product Data Sheet at 18 inches and 7000 pounds.

### CALCULATING DYNAMIC LOAD

The curves on the Dynamic Load vs. Deflection Chart (Section 4) can be calculated using the formulas developed in Section 6. It is helpful to construct a table of values as shown below.

	Height (in)	Static Load (lb)	Volume (cu in)	Effective Area (sq in)	Absolute Pressure (psia)	Gauge Pressure (psig)	Dynamic Load (lb)	G's
Line <b>3</b>	21							
Line <b>1</b>	18							
Line <b>2</b>	15							

The 1T15M-11 on an M-9 piston is used for this example (W01-358-9320). Refer to that Product Data Sheet.

Conditions selected:

Air spring load = 4000 lb  
Design height = 18 inches

Find:

Dynamic load at + 3 inch compression  
Dynamic load at - 3 inch extension

Line **1** is the selected design condition.

Line **2** is the data for 3 inch compression.

Line **3** is the data for 3 inch extension.

**Note:** For loads between constant pressure curves, calculate the effective area by using the load on the closest constant pressure curve. Then calculate the pressure by dividing the design load by the effective area.

Line **1** entries are determined as follows (Design):

**Static Load**, This value is obtained on the closest constant pressure curve, 60 psig in this case, at the 18 inch design height. Refer to the Static Load Deflection Curve.

$$L = 4200 \text{ lb}$$

**Volume**, This value is taken from the 100 psig Data Table at 18 inch height.

$$V_1 = 1207.89 \text{ cu in}$$

**Effective Area**, Calculated at 60 psig and 18 inch height.

$$A_1 = \frac{\text{Load}}{\text{Pressure}} = \frac{4200}{60} = 70 \text{ in}$$

**Gauge Pressure**, The Design Load divided by the effective area.

$$P_{g1} = \frac{L}{A} = \frac{4000}{70} = 57.14 \text{ psig}$$

**Absolute Pressure**, Gauge pressure + 14.7.

$$P_{a1} = P_{g1} + 14.7 = 57.14 + 14.7 = 71.84 \text{ psia}$$

**Dynamic Load** at point 1, equals the Design Load = 4000 lb.

Enter these values in the data chart constructed.

Now calculate the values for Line **2** (3 inch compression):

**Static Load**, From the 60 psig constant pressure curve and 15 inch design height.

$$L = 4200 \text{ lb}$$

**Volume**, From the 100 psig Data Table at 15 inch height.

$$V_2 = 981.62 \text{ cu in}$$

**Effective Area**, At 60 psig and 15 inch height.

$$A_2 = \frac{\text{Load}}{\text{Pressure}} = \frac{4200}{60} = 70 \text{ in}$$

**Absolute Pressure**, Use the polytropic gas law.

$$P_{a2} = P_{a1} \left( \frac{V_1}{V_2} \right)^n = 71.84 \left( \frac{1207.89}{981.62} \right)^{1.38}$$

$$P_{a2} = 95.65 \text{ psia}$$

**Gauge Pressure**, Absolute pressure – 14.7.

$$P_{g2} = P_{a2} - 14.7 = 95.65 - 14.7 = 80.94 \text{ psig}$$

**Dynamic Load**, Effective area x pressure.

$$DL_2 = P_{g2} \times A_2 = 80.94 \times 70 = 5666 \text{ lb}$$

**G's**, The ratio of Dynamic Load to Design Load.

$$G = \frac{DL_2}{L} = \frac{5666}{4000} = 1.42$$

Enter these values in the data chart constructed.

Now calculate the values for Line **3** (3 inch extension):

**Static Load**, From the 60 psig constant pressure curve and 21 inch design height.

$$L = 4000 \text{ lb}$$

**Volume**, From the 100 psig Data Table and 21 inch height.

$$V_3 = 1419.72 \text{ cu in}$$

**Effective Area**, At 60 psig and 21 inch height.

$$A_3 = \frac{\text{Load}}{\text{Pressure}} = \frac{4000}{60} = 66.67$$

**Absolute Pressure**, Use the polytropic gas law.

$$P_{a3} = P_{a1} \left( \frac{V_1}{V_3} \right)^n = 71.84 \left( \frac{1207.89}{1419.72} \right)^{1.38} = 57.48 \text{ psia}$$

**Gauge Pressure**, Absolute pressure – 14.7.

$$P_{g3} = P_{a3} - 14.7 = 57.48 - 14.7 = 42.78 \text{ psig}$$

**Dynamic Load**, Effective area x pressure.

$$DL_3 = P_{g3} \times A_3 = 42.78 \times 70 = 2852 \text{ lb}$$

**G's**, The ratio of Dynamic Load to Design Load.

$$G = \frac{DL_3}{L} = \frac{2852}{4000} = .71$$

A plot of the dynamic load points vs. height will give the curve shown on the Product Data Sheet, Dynamic Load vs. Deflection Chart with a starting point of 18 inch height and 60 psig.

The completed table of values is shown below:

	Height (in)	Static Load (lb)	Volume (cu in)	Effective Area (sq in)	Absolute Pressure (psia)	Gauge Pressure (psig)	Dynamic Load (lb)	G's
Line <b>3</b>	21	4000	1419.72	66.67	57.48	42.78	2852	0.71
Line <b>1</b>	18	4200	1207.89	70	71.84	57.14	4000	1.0
Line <b>2</b>	15	4200	981.62	70	95.65	80.94	5666	1.42



### TRAILING ARM SUSPENSION CALCULATIONS

The trailing arm design is a common truck and trailer air suspension. The air spring does not carry the same load that is applied at the wheel (axle). The formulas developed in Section 6 are used.

One method of obtaining a trial suspension design follows for a 20,000 lb axle, using a 1T15M-6 reversible sleeve air spring at 13 inch height.

Determine the necessary trailing arm ratio needed to support the axle design load within the air spring maximum allowed static pressure of 100 psig which creates a lifting force of 7,045 lb at a 13 inch height. See Product Data Sheet (W01-358-9082).

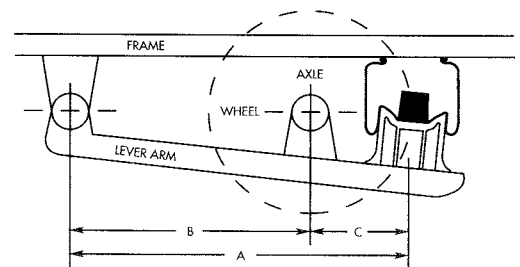

Assume an unsprung weight of 800 lb

Load at wheel  $L_w = (20,000 - 800) \div 2 = 9600$  lb.

$$\text{LAR} = \frac{L_w}{L_s} = \frac{9600}{7045} = 1.36 \text{ using the M-6 at 100 psig}$$

For this example a 90 psig operating pressure will be used.

$$\text{LAR} = \frac{L_w}{L_s} = \frac{9600}{6340} = 1.52 \text{ using the M-6 at 90 psig}$$

Note, the 6340 lb at 90 psig is calculated by multiplying the pressure ratio times the load at 100 psig, or:

$$\frac{90}{100} \times 7045 = 6340 \text{ lb}$$

Now using the maximum OD of the M-6, 12.6 inches, and an assumed axle diameter of 5 inches plus a minimum clearance of one inch, calculate the dimension "C" shown in the illustration on page 56:

$$C = (1/2 \times \text{OD air spring} + 1/2 \times \text{axle diameter}) + \text{clearance}$$

$$C = \left( \frac{12.6}{2} + \frac{5}{2} \right) + 1 = 9.8 \text{ inch}$$

Calculating dimension "C" in this manner places the air spring as close to the axle as possible, which provides the lowest rate and frequency at the wheel (with the air spring aft of the axle).

Now calculate dimensions "A" and "B" with LAR = 1.52 and C = 9.8:

$$\text{LAR} = \frac{A}{B} = 1.52 = \frac{B+C}{B} = \frac{B+9.8}{B}$$

$$1.52B - B = 9.8$$

$$B = \frac{9.8}{.52} = 18.85 \text{ inch}$$

Then determine A:

$$A = B + C = 18.85 + 9.8 = 28.65 \text{ inch}$$

Note that with a given "B" dimension (e.g., 21 inches) determined by other factors, proceed as follows:

$$\text{LAR} = 1.52 = \frac{A}{B}$$

$$A = 1.52 B = 1.52 \times 21 = 31.9$$

Then check for clearance at the axle:

$$C = A - B = 31.9 - 21 = 10.9 \text{ which is greater than } 9.8$$

The following is now known for the sample situation:

- 20,000 lb axle rating
- Load at wheel = 9600 lb
- Load at the spring = 6340 lb
- LAR = 1.52
- Distance from pivot to spring = 28.65 inch
- Distance from pivot to axle = 18.85 inch
- Design height = 13 inch

The system characteristics may now be calculated using the preceding results with data from the Product Data Sheet 1T15M-6 (W01-358-9082).

$$A_1 = \frac{7045}{100} = 70.45 \text{ in (at 13 inch height)}$$

$$A_c = \frac{7050}{100} = 70.5 \text{ in (at 12.5 inch height)}$$

$$A_e = \frac{7042}{100} = 70.42 \text{ in (at 13.5 inch height)}$$

$$V_1 = 917.41 \text{ cu in (at 13 inch height)}$$

$$V_c = 879.31 \text{ cu in (at 12.5 inch height)}$$

$$V_e = 955.30 \text{ cu in (at 13.5 inch height)}$$

Now calculate the pressure at the 13 inch height:

$$P_{g1} = \frac{L_1}{A_1} = \frac{6340}{70.45} = 90 \text{ psig}$$

Air Spring Rate:

$$K_s = P_{a1} \left[ A_c \left( \frac{V_1}{V_c} \right)^{1.38} - A_e \left( \frac{V_1}{V_e} \right)^{1.38} \right] - 14.7(A_c - A_e)$$

$$K_s = (90 + 14.7) \left[ 70.5 \left( \frac{917.41}{879.31} \right)^{1.38} - 70.42 \left( \frac{917.41}{955.3} \right)^{1.38} \right] - 14.7(70.5 - 70.42)$$

$$K_s = 104.7 [74.75 - 66.59] - 1.176$$

$$K_s = 854.35 - 1.176 = 853.2 \text{ lb/in}$$

Air Spring Frequency:

$$f_s = 188 \sqrt{\frac{K_s}{W}} = 188 \sqrt{\frac{853.2}{6340}} = 68.97 \text{ cpm}$$

Wheel Rate:

$$K_w = K_s (\text{LAR})^2$$

$$K_w = 853.2 (1.52)^2 = 1971 \text{ lb/in}$$

Wheel Frequency:

$$f_w = f_s (\text{LAR})^{1/2}$$

$$f_w = 68.97 (1.52)^{1/2} = 85 \text{ cpm}$$

Other factors that must be considered include, but are not limited to:

- Maximum extension
- Minimum height
- Stroke at the axle



# SAMPLE CALCULATIONS USING A PERSONAL COMPUTER

3

```

FIRESTONE INDUSTRIAL PRODUCTS COMPANY
Carmel, Indiana 46032

Date       : Jan 1, 1993
Part Number : 1T15M-11 on M-9 piston
Test Request # : B-0699
Design Height : 18.00
Bumper Volume : 0.00          STATIC - RATE and FREQUENCY
Bumper No.   : n/a
Load start   : 2500
Load increment : 250
    
```

4

```

-----
18.00 inch DESIGN HEIGHT
-----
A1 = 71.46 sq in      V1 = 1207.89 cu in
Ac = 71.46 sq in      Vc = 1170.92 cu in
Ae = 71.46 sq in      Ve = 1244.46 cu in
    
```

5

LOAD (lb)	PRESSURE (psig)	RATE (lb/in)	FREQUENCY (cpm)
2500	35.0	298.8	64.9
2750	38.5	319.8	64.0
3000	42.0	340.9	63.2
3250	45.5	361.9	62.6
3500	49.0	382.9	62.1
3750	52.5	404.0	61.6
4000	56.0	425.0	61.2
4250	59.5	446.1	60.8
4500	63.0	467.1	60.5
4750	66.5	488.1	60.2
5000	70.0	509.2	59.9
5250	73.5	530.2	59.6
5500	77.0	551.3	59.4
5750	80.5	572.3	59.2
6000	84.0	593.3	59.0
6250	87.5	614.4	58.8
6500	91.0	635.4	58.7
6750	94.5	656.5	58.5
7000	98.0	677.5	58.4
7250	101.5	698.5	58.2

(Sample File STATSPL.WK1)

## STATIC RATE AND FREQUENCY

### INSTRUCTIONS

In this example you will calculate the static rate and frequency of the 1T15M-11 (W01-358-9320) reversible sleeve style air spring on an M-9 piston at an 18 inch design height.

- 1 Load \*Lotus 1-2-3 or file compatible spreadsheet.
- 2 Load the file named STATCALC.WK1 from the disk provided. Save the file with a new name (for example M11DH18) on a separate data disk.
- 3 Enter the information:

- Date (Label)
- Part Number (Label)
- Test Request # (Label)
- Design Height (Value)
- Bumper Volume (Value)
- Bumper Number (Label)
- Load start (Value)
- Load increment (Value)

\*Lotus 1-2-3 is a registered trademark of Lotus Development Corp.



---

**4** Enter the areas (sq in) and volumes (cu in):

- A1 is the effective area at the design height.
- Ac is the effective area at  $\frac{1}{2}$  inch below design height.
- Ae is the effective area at  $\frac{1}{2}$  inch above design height.
- V1 is the internal volume at the design height.
- Vc is the volume at  $\frac{1}{2}$  inch below the design height.
- Ve is the volume at  $\frac{1}{2}$  inch above the design height.

*Note: All entries are values. If a bumper is used, subtract the bumper volume from V1, Vc, and Ve. Refer to the Bumper Volume Chart on page 36.*

---

**5** The pressure, rate and frequency are automatically calculated for the loads selected.

---

**6** Save the file with the new file name selected in Step 2.

3	<pre> FIRESTONE INDUSTRIAL PRODUCTS CO. Carmel, Indiana 46032  Date       : Jan 1, 1993 Part Number : 1T15M-11 on M-9 piston Test Request # : 0-0689 Design Height : 18.00 Bumper Volume : 0.00          STATIC - WHEEL Bumper Number : n/a          RATE and FREQUENCY </pre>																												
4	<pre> ----- 18.00 inch DESIGN HEIGHT ----- Al = 71.46 sq in          V1 = 1207.89 cu in Ac = 71.46 sq in          Vc = 1170.92 cu in Ae = 71.46 sq in          Ve = 1244.46 cu in </pre>																												
5	<table border="0"> <thead> <tr> <th>LOAD</th> <th>PRESSURE</th> <th>RATE</th> <th>FREQUENCY</th> </tr> <tr> <th>(lb)</th> <th>(psig)</th> <th>(lb/in)</th> <th>(cpm)</th> </tr> <tr> <th>----</th> <th>----</th> <th>----</th> <th>----</th> </tr> </thead> <tbody> <tr> <td>2500</td> <td>35.0</td> <td>298.8</td> <td>64.9</td> </tr> <tr> <td>4000</td> <td>56.0</td> <td>425.0</td> <td>61.2</td> </tr> <tr> <td>5500</td> <td>77.0</td> <td>551.3</td> <td>59.4</td> </tr> <tr> <td>7000</td> <td>98.0</td> <td>677.5</td> <td>58.4</td> </tr> </tbody> </table>	LOAD	PRESSURE	RATE	FREQUENCY	(lb)	(psig)	(lb/in)	(cpm)	----	----	----	----	2500	35.0	298.8	64.9	4000	56.0	425.0	61.2	5500	77.0	551.3	59.4	7000	98.0	677.5	58.4
LOAD	PRESSURE	RATE	FREQUENCY																										
(lb)	(psig)	(lb/in)	(cpm)																										
----	----	----	----																										
2500	35.0	298.8	64.9																										
4000	56.0	425.0	61.2																										
5500	77.0	551.3	59.4																										
7000	98.0	677.5	58.4																										
6	<pre> A = Pivot to spring = 35 B = Pivot to axle   = 24 </pre>																												
7	<pre> A/B = Lever Arm Ratio = 1.46 LAR exponent 2         = 2.13 LAR exponent 0.5       = 1.21 </pre>																												
8	<table border="0"> <thead> <tr> <th>LOADs</th> <th>RATEs</th> <th>FREQs</th> </tr> <tr> <th>----</th> <th>----</th> <th>----</th> </tr> </thead> <tbody> <tr> <td>2500</td> <td>298.8</td> <td>64.9</td> </tr> <tr> <td>4000</td> <td>425.0</td> <td>61.2</td> </tr> <tr> <td>5500</td> <td>551.3</td> <td>59.4</td> </tr> <tr> <td>7000</td> <td>677.5</td> <td>58.4</td> </tr> </tbody> </table>	LOADs	RATEs	FREQs	----	----	----	2500	298.8	64.9	4000	425.0	61.2	5500	551.3	59.4	7000	677.5	58.4										
LOADs	RATEs	FREQs																											
----	----	----																											
2500	298.8	64.9																											
4000	425.0	61.2																											
5500	551.3	59.4																											
7000	677.5	58.4																											
9	<table border="0"> <thead> <tr> <th>LOADw</th> <th>RATEw</th> <th>FREQw</th> </tr> <tr> <th>----</th> <th>----</th> <th>----</th> </tr> </thead> <tbody> <tr> <td>3646</td> <td>635.5</td> <td>78.3</td> </tr> <tr> <td>5833</td> <td>903.9</td> <td>73.9</td> </tr> <tr> <td>8021</td> <td>1172.4</td> <td>71.7</td> </tr> <tr> <td>10208</td> <td>1440.9</td> <td>70.5</td> </tr> </tbody> </table>	LOADw	RATEw	FREQw	----	----	----	3646	635.5	78.3	5833	903.9	73.9	8021	1172.4	71.7	10208	1440.9	70.5										
LOADw	RATEw	FREQw																											
----	----	----																											
3646	635.5	78.3																											
5833	903.9	73.9																											
8021	1172.4	71.7																											
10208	1440.9	70.5																											

(Sample File WHFRQSPL.WK1)

## STATIC WHEEL RATE & FREQUENCY

### INSTRUCTIONS

In this example you will calculate the wheel frequency of the 1T15M-11 (W01-358-9320) reversible sleeve style air spring on an M-9 piston at an 18 inch design position.

- 1** Load \*Lotus 1-2-3 or file compatible spreadsheet.
- 2** Load the file named WHFREQ.WK1 from the disk provided. Save the file with a new name (for example M11WFREQ) on a separate data disk.
- 3** Enter the information:
  - Date (Label)
  - Part Number (Label)
  - Test Request # (Label)
  - Design Height (Value)
  - Bumper Volume (Value)
  - Bumper Number (Label)

\*Lotus 1-2-3 is a registered trademark of Lotus Development Corp.

---

**4** Enter the areas (sq in) and volumes (cu in):

- A1 is the effective area at the design height.
- Ac is the effective area at 1/2 inch below the design height.
- Ae is the effective area at 1/2 inch above the design height.
- V1 is the internal volume at the design height.
- Vc is the volume at 1/2 inch below the design height.
- Ve is the volume at 1/2 inch above the design height.

*Note: All entries are values. If a bumper is used, subtract the bumper volume from V1, Vc, and Ve. Refer to the Bumper Volume Chart on page 36.*

---

**5** Enter four air spring loads that might be of interest to you. The air spring pressure, rate, and frequency are automatically calculated for the loads you selected.

---

**6** Enter the suspension dimensions. Dimension A is the distance from the pivot to the spring center line. Dimension B is the distance from the pivot to the axle center line.

---

**7** The lever arm ratio, its square and square root are calculated and used in the calculations for loads, rates and frequencies.

---

**8** The air spring loads, rates and frequencies are repeated.

---

**9** The wheel (axle) loads, rates, and frequencies are calculated. Change the loads in step 5 to obtain any desired wheel loads.

---

**10** Save the file with the new name you selected in Step 2.

FIRESTONE INDUSTRIAL PRODUCTS COMPANY  
Carmel, Indiana 46032

③ Date : Jan 1, 1993  
Part Number : 1T15M-11 on M-9 piston  
Test Request # : B-0689  
Design Height : 18 DYNAMIC LOAD CALCULATION  
Design Load : 7146  
Pressure : 100

Height (in)	Static Load at		Volume at 100 psig (cu in)	Effective Area (sq in)	Abs Press (psia)	Gauge Press (psig)	Dynamic Load (lb)	G/m
	Psig (lb)	100 psig						
④ 22.0	6503	1485.47	65.03	86.22	71.52	4651		
21.5	6700	1452.95	67.00	88.89	74.19	4971		
21.0	6857	1419.72	68.57	91.77	77.07	5285		
20.5	6975	1385.82	69.75	94.89	80.19	5593		
20.0	7059	1351.30	70.59	98.25	83.55	5898		
19.5	7113	1316.21	71.13	101.88	87.18	6201		
19.0	7140	1280.57	71.40	105.81	91.11	6506		
⑤ 18.5	7146	1244.46	71.46	110.07	95.37	6815		
18.0	7146	1207.89	71.46	114.70	100.00	7146	design	
17.5	7146	1170.92	71.46	119.73	105.03	7505	1.05	
17.0	7146	1133.61	71.46	125.20	110.50	7896	1.10	
16.5	7146	1095.97	71.46	131.17	116.47	8323	1.16	
16.0	7146	1058.06	71.46	137.70	123.00	8790	1.23	
15.5	7146	1019.93	71.46	144.86	130.16	9301	1.30	
15.0	7146	981.62	71.46	152.71	138.01	9862	1.38	
14.5	7146	943.18	71.46	161.37	146.67	10481	1.47	
14.0	7146	904.64	71.46	170.93	156.23	11164	1.56	
13.5	7146	866.05	71.46	181.53	166.83	11922	1.67	
13.0	7233	827.46	72.33	193.32	178.62	12919	1.81	
12.5	7334	788.91	73.34	206.47	191.77	14065	1.97	
12.0	7453	750.44	74.53	221.22	206.52	15392	2.15	

(Sample File DYN SPL1.WK1)

## DYNAMIC LOAD

### INSTRUCTIONS

In this example you will calculate the dynamic load for the 1T15M-11 (WO1-358-9320) reversible sleeve style air spring on an M-9 piston at an 18 inch design position and a load of 7,146 lb.

- ① Load \*Lotus 1-2-3 or file compatible spreadsheet.
- ② Load the file named DYNAMIC.WK1 from the disk provided. Save the file with a new name (for example, M11DYN18) on a separate data disk.
- ③ Enter the information:
  - Date (Label)
  - Part Number (Label)
  - Test Request # (Label)
  - Design Height (Value)
  - Design Load (Value)
  - Pressure (Which constant pressure curve used) (Value)

\*Lotus 1-2-3 is a registered trademark of Lotus Development Corp.

---

**4** At each height, enter the load from the constant pressure curve closest to the design load. Take this information from the Product Data Sheet. In this example, the design load selected was that at 100 psig. In general, volume data is available only at 100 psig, and is used for all loads. Enter the volume data from the 100 psig static data chart on the Product Data Sheet at each height. Subtract the bumper volume if applicable.

---

**5** The following are automatically calculated at each height:

- Air spring effective area (sq in)
- Air spring absolute pressure (psia)
- Air spring gauge pressure (psig)
- Air spring dynamic load (lb)
- G's for compression heights (a ratio of dynamic load to design load)

A dynamic load vs. height plot will give the results of the Dynamic Load vs. Deflection Chart on the 1T15M-11 Data Sheet, part number 9320.

---

**6** Save the file with the new file name selected in Step 2.

FIRESTONE INDUSTRIAL PRODUCTS COMPANY  
Carmel, Indiana 46032

3 Date : Jan 1, 1993  
Part Number : 1T15M-11 on M-9 piston  
Test Request # : N-0689  
Design Height : 18  
Design Load : 4000  
Pressure : 60

DYNAMIC LOAD CALCULATION

Height (in)	Static Load at 60 psig (lb)	Volume at 100 psig (cu in)	Effective Area (sq in)	Abs Press (psia)	Gauge Press (psig)	Dynamic Load (lb)	G's
22.0	3750	1485.47	62.50	54.00	39.30	2456	
21.5	3900	1452.95	65.00	55.68	40.98	2664	
21.0	4000	1419.72	66.67	57.48	42.78	2852	
20.5	4100	1385.82	68.33	59.43	44.73	3057	
20.0	4150	1351.30	69.17	61.54	46.84	3240	
19.5	4175	1316.21	69.58	63.81	49.11	3417	
19.0	4200	1280.57	70.00	66.28	51.58	3610	
18.5	4200	1244.46	70.00	68.95	54.25	3797	
18.0	4200	1207.89	70.00	71.84	57.14	4000	design
17.5	4200	1170.92	70.00	74.99	60.29	4220	1.06
17.0	4200	1133.61	70.00	78.42	63.72	4460	1.12
16.5	4200	1095.97	70.00	82.16	67.46	4722	1.18
16.0	4200	1058.06	70.00	86.25	71.55	5008	1.25
15.5	4200	1019.93	70.00	90.73	76.03	5322	1.33
15.0	4200	981.62	70.00	95.65	80.95	5667	1.42
14.5	4200	943.18	70.00	101.07	86.37	6046	1.51
14.0	4200	904.64	70.00	107.06	92.36	6466	1.62
13.5	4200	866.05	70.00	113.70	99.00	6930	1.73
13.0	4250	827.46	70.83	121.09	106.39	7536	1.88
12.5	4300	788.91	71.67	129.33	114.63	8215	2.05
12.0	4350	750.44	72.50	138.56	123.86	8980	2.25

4

5

(Sample File DYN SPL2.WK1)

## DYNAMIC LOAD

### INSTRUCTIONS

In this example you will calculate the dynamic load for the 1T15M-11 (WO1-358-9320) reversible sleeve style air spring on an M-9 piston at an 18 inch design position and a load of 4,000 lb.

**1** Load \*Lotus 1-2-3 or file compatible spreadsheet.

**2** Load the file named DYNAMIC.WK1 from the disk provided. Save the file with a new name (for example, M11DYN2) on a separate data disk.

**3** Enter the information:

- Date (Label)
- Part Number (Label)
- Test Request # (Label)
- Design Height (Value)
- Design Load (Value)
- Pressure (Which constant pressure curve used) (Value)

\*Lotus 1-2-3 is a registered trademark of Lotus Development Corp.

---

**4** At each height, enter the load from the constant pressure curve closest to the design load. Take this information from the Product Data Sheet. In this example, the design load of 4,000 lb is closest to the 60 psig curve. In general, volume data is available only at 100 psig and is used for all loads. Enter the volume data from the 100 psig static data chart on the Product Data Sheet at each height. Subtract the bumper volume if applicable.

---

**5** The following are automatically calculated at each height:

- Air spring effective area (sq in)
- Air spring absolute pressure (psia)
- Air spring gauge pressure (psig)
- Air spring dynamic load (lb)
- G's for compression heights (a ratio of dynamic load to design load)

A dynamic load vs height plot will give the results of the Dynamic Load vs. Deflection Chart on the 1T15M-11 Data Sheet, part number 9320.

---

**6** Save the file with the new file name selected in Step 2.



## **WARRANTY CONSIDERATIONS**

### **INTRODUCTION**

Firestone air springs are designed to provide years and thousands of miles of trouble-free service. The durability of Firestone air springs is such that they will often outlast other maintenance items on your suspension, such as bushings, shocks, leveling valves or regulators.

Airide® springs by Firestone are \*warranted to be free of material defects and/or workmanship for various periods of time, depending upon the application. Replacements may be provided by the original suspension manufacturer, manufacturer's representative or dealer, or by any Firestone air spring distributor. All labor and incidental costs associated with replacing the defective air spring are the responsibility of the purchaser, or end user.

Firestone Industrial Products Company offers a complete line of Airide springs, with replacement springs available for virtually every vehicular air suspension system.

Since each individual air spring is closely examined and pressure tested at the factory, the vast majority of premature failures and consequent warranty returns are found not to be defective, but fail because of abuse caused by other problems associated with the suspension.

Before you install a new air spring, you should carefully examine the old one to determine what caused it to fail. If it was due to a defect in the suspension system, then the new air spring will also fail unless you correct the problem.

The information that follows was developed to illustrate the types of failures that may occur, and to assist you in determining the cause and corrective action required.

\*Complete warranty information may be obtained from any Firestone Airide air spring distributor or by calling 1-800-247-4337.



Most air spring failures are caused by a lack of suspension maintenance or improper application. This is a guide to common failures that are *not* covered by warranty.

### **MISALIGNMENT**

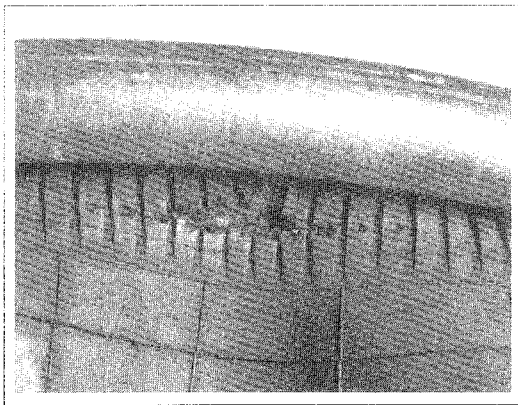

#### **Appearance Or Condition**

- Off-center bumper contact
- Same as bottoming out or abrasion (See pages 74 and 75)



#### **Possible Causes**

- Worn bushing
- Improper installation

### LOOSE GIRDLE HOOP

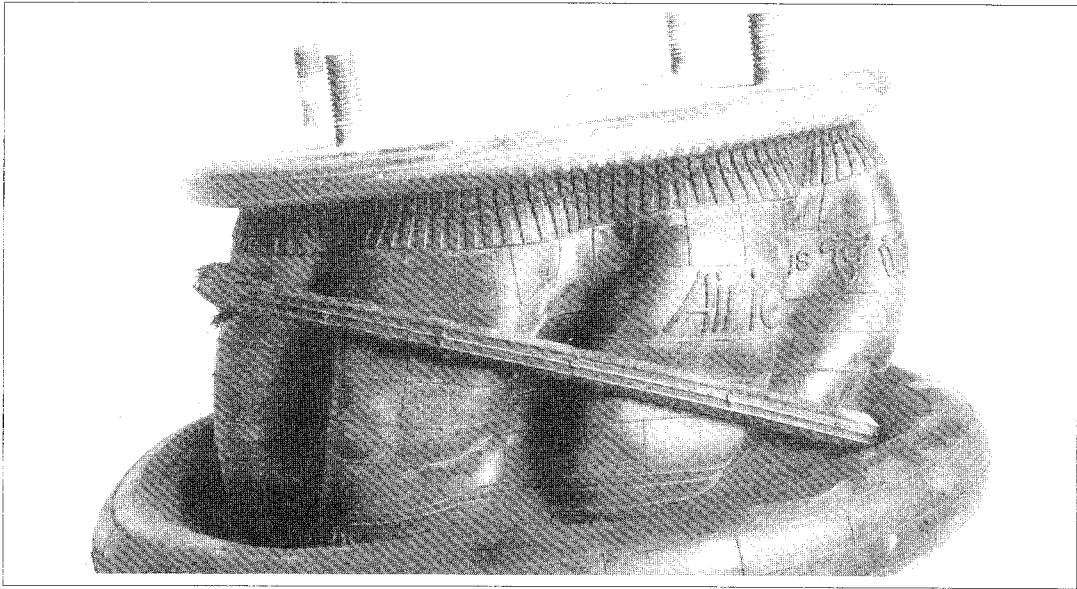

---

#### Appearance Or Condition

---

- Flexible member distorted and girdle hoop torn loose

---

#### Possible Causes

---

- Running at extended positions with low air pressure

## BOTTOMING OUT

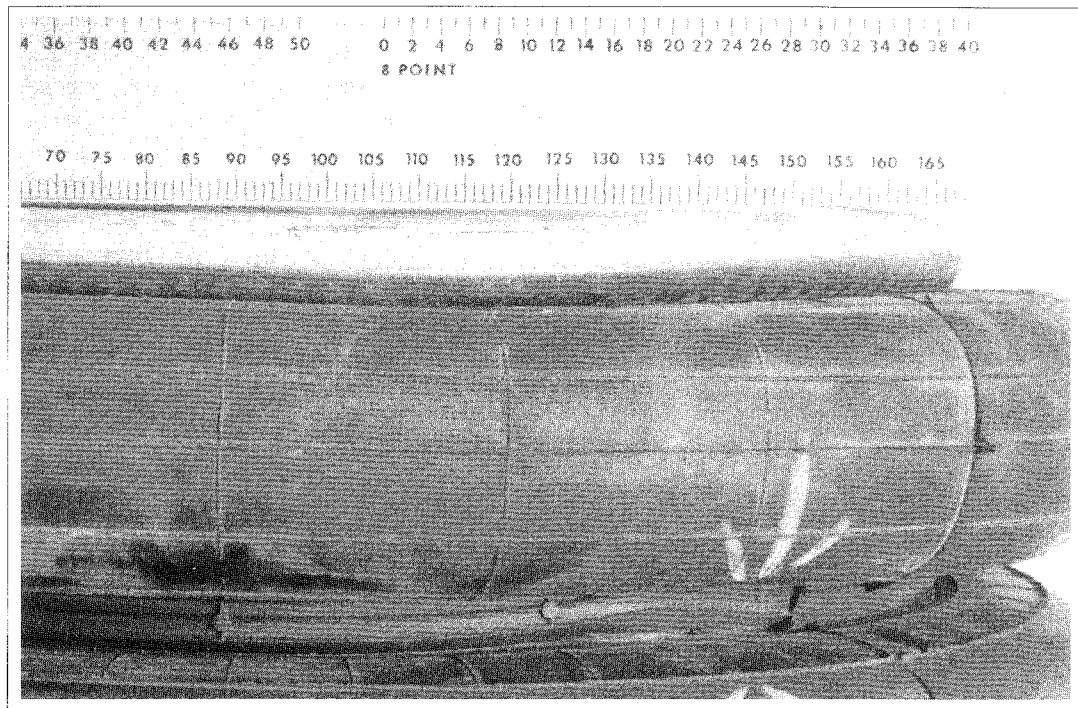

Appearance or Condition	Possible Causes
• Bead plate concave	• Broken or defective shock absorber
• Internal bumper loose	• Defective leveling valve
• Hole in girdle hoop area (convoluted)	• Overloaded vehicle
• Hole in bead plate junction area	• Pressure regulator set too low
• Leaking around blind nuts	• Wrong air spring (too tall)

## ABRASION

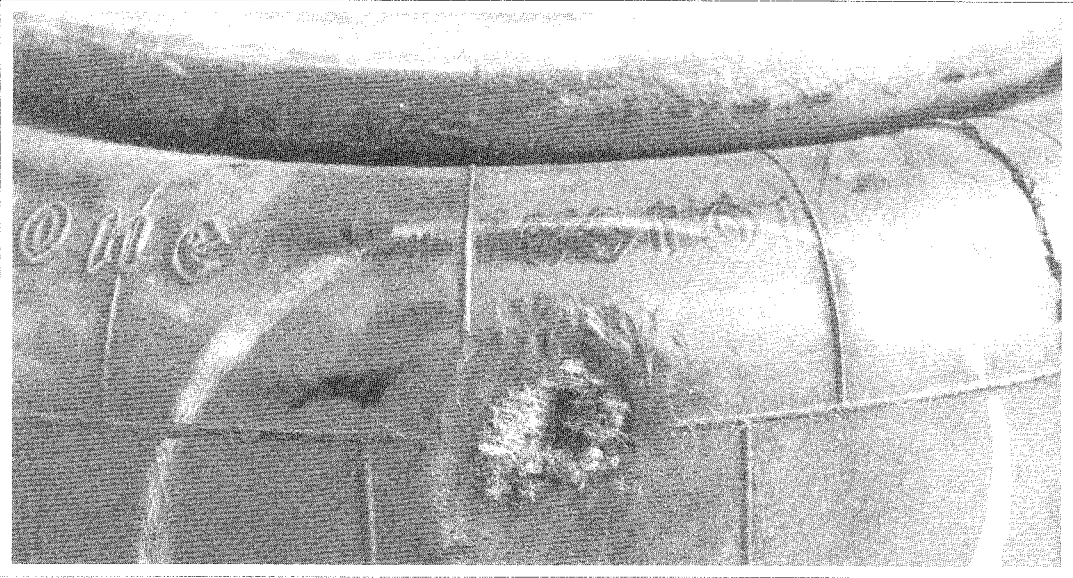

### Appearance Or Condition

- Hole rubbed into side of flexible member
- Hole in flexible member area that rolls over piston (reversible sleeve style air springs)

### Possible Causes

- Structural interference such as:
  - broken shock
  - misalignment
  - loose air line
  - worn bushings
- No air pressure (reversible sleeve style)
- Foreign material (sand, rocks, etc.)
- Wrong air spring

## CIRCUMFERENTIAL CUTS

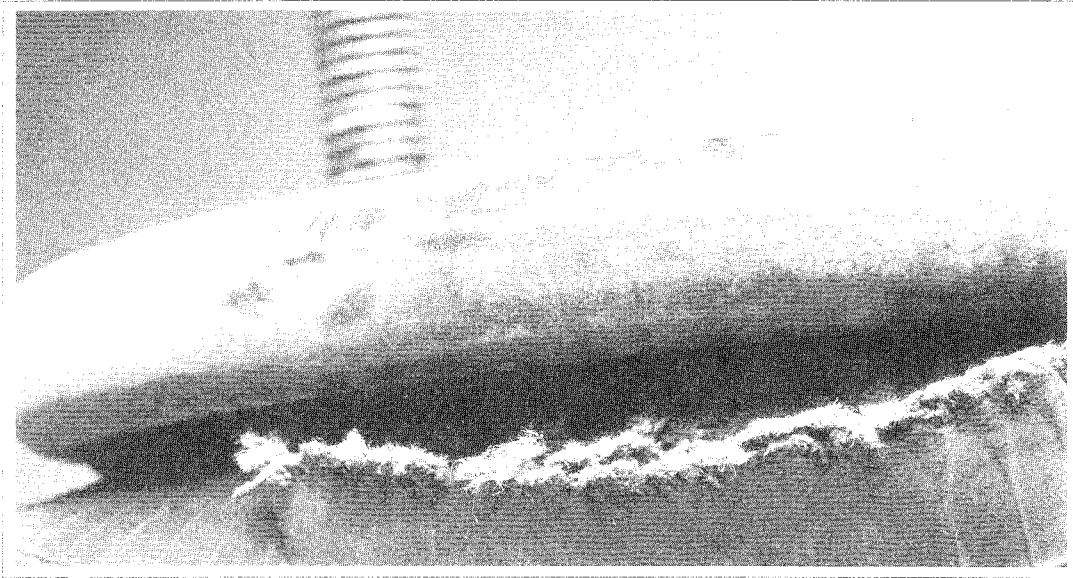

---

### Appearance Or Condition

---

- Flexible member cut in circle at bead plate junction
  - Flexible member cut in circle at piston junction (reversible sleeve style)
- 

---

### Possible Causes

---

- High pressure, fully extended for long periods of time
  - Impact in compressed position
-

## OVER-EXTENSION

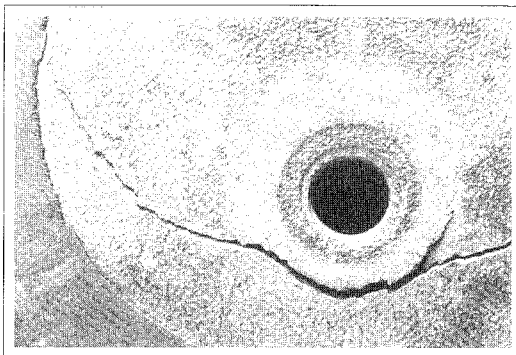
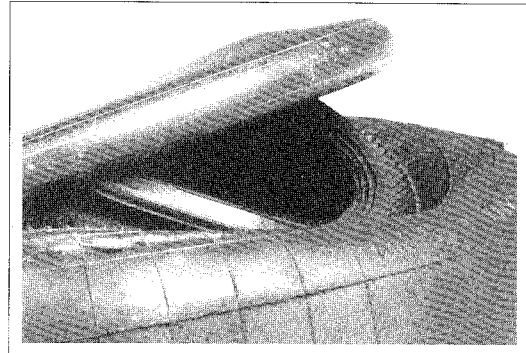
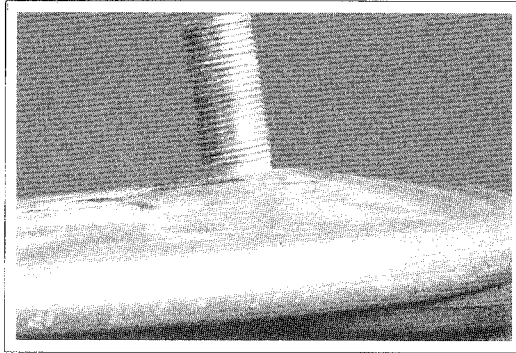

### Appearance Or Condition

- Bead plate convex, especially around blind nuts or studs
- Flexible member separated from bead plate
- Leaking at blind nuts or studs
- Leaking at end closure (reversible sleeve type)
- Loose girdle hoop on convoluted style

### Possible Causes

- Broken or wrong shock absorber
- Defective leveling valve
- Ride position too high
- Defective upper stop (lift)
- Wrong air spring (too short)

## **PREVENTIVE MAINTENANCE CHECKLIST**

The following items should be checked when the vehicle is in for periodic maintenance.

**WARNING: Never attempt to service an air suspension with the air springs inflated.**

**1**

Inspect the O.D. of the air spring. Check for signs of irregular wear or heat cracking.

**2**

Inspect air lines to make sure contact doesn't exist between the air line and the O.D. of the air spring. Air lines can rub a hole in an air spring very quickly.

**3**

Check to see that there is sufficient clearance around the complete circumference of the air spring while it is at its maximum diameter.

**4**

Inspect the O.D. of the piston for buildup of foreign materials. (On a reversible sleeve style air spring, the piston is the bottom component of the air spring).

**5**

Correct ride height should be maintained. All vehicles with air springs have a specified ride height established by the O.E.M. manufacturer. This height, which is found in your service manual, should be maintained within 1/4". This dimension can be checked with the vehicle loaded or empty.

**6**

Leveling valves (or height control valves) play a large part in ensuring that the total air spring system works as required. Clean, inspect and replace, if necessary.

**7**

Make sure you have the proper shock absorbers and check for leaking hydraulic oil and worn or broken end connectors. If a broken shock is found, replace it immediately. The shock absorber will normally limit the rebound of an air spring and keep it from overextending.

**8**

Check the tightness of all mounting hardware (nuts and bolts). If loose, re-torque to the manufacturer's specifications. Do not over-tighten.



## **CLEANING**

---

### **APPROVED METHODS**

---

Approved cleaning media are soap and water, methyl alcohol, ethyl alcohol and isopropyl alcohol.

---

### **NON-APPROVED METHODS**

---

Non-approved cleaning media include all organic solvents, open flames, abrasives and direct pressurized steam cleaning.

**PLEASE NOTE:** The total inspection process of the air springs on your vehicle can be performed in a matter of minutes. If any of the conditions described on the previous page exists, please take corrective action to ensure that your air springs will perform properly. It will save you both time and money in the long run.







**SUGGESTED READING**

SAE Information Report, First Edition, June 1988, SAE HS 1576, *Manual for Incorporating Pneumatic Springs in Vehicle Suspension Designs* (Warrendale, PA: Society of Automotive Engineers, Inc., 1988).

Thomas D. Gillespie, *Fundamentals of Vehicle Dynamics* (Warrendale, PA: Society of Automotive Engineers, Inc., 1992).

Robert K. Vierck, *Vibration Analysis*, 2nd ed. (New York: Harper & Row, 1979).

## **HISTORY**

In the early 1930's, the Firestone Tire and Rubber Company began experiments to develop the potential of pneumatic springs.

Between 1935 and 1939, several makes of U.S. automobiles were equipped with air springs and extensively tested to prove the potential of automotive air suspension systems. They were never put into production, however, because significant developments in steel spring design gave an improved ride at much lower cost than the air spring system at that time.

In 1938, the country's largest manufacturer of motor coaches became interested in using air springs on a new design bus they were developing. Working with Firestone engineers, the first busses were tested in 1944 and the inherent ride superiority of air suspensions was clearly documented.

In the early 1950's, after several years of intensive product development, the air sprung bus finally went into production. That was the beginning of the Airide® air spring success story.

The success of air springs in bus applications spurred new interest in truck and trailer applications as well as industrial shock and vibration isolation uses. Consequently, almost all of the busses, most of the Class 8 trucks and many of the trailers on the road today now ride on air springs, and significant advances in the design of control systems have opened the door to automotive applications as well.



### COMPANY HEADQUARTERS

Firestone Industrial Products Company  
701 Congressional Boulevard  
Carmel, IN 46032  
Phone: (317) 580-2300  
Toll free: 1-800-AIRIDES  
FAX: (317) 580-2345

### SALES OFFICES

#### U.S.A.

Firestone Industrial Products Company  
701 Congressional Boulevard  
Carmel, IN 46032  
Phone: (317) 580-2300  
Toll free: 1-800-AIRIDES  
FAX: (317) 580-2345

Firestone Industrial Products Company  
26777 Central Park Boulevard  
Suite 250  
Southfield, MI 48076  
Phone: (313) 353-4205  
FAX: (313) 353-0995

#### Europe

Firestone Industrial Products Company  
26A High Street  
Hounslow Middlesex TW3 1NW  
England  
Phone: 44-81-572-2240  
FAX: 44-81-572-7489

#### South America

Firestone Produtos Industriais Ltda.  
Av. Queiros dos Santos, 1419  
09015 Santo Andre  
Sao Paulo, Brazil  
Phone: 55-11-411-1166  
FAX: 55-11-454-7328

### MANUFACTURING LOCATIONS

#### Noblesville, Indiana

Firestone Industrial Products Company  
1700 Firestone Boulevard  
Noblesville, IN 46060  
Phone: (317) 773-0650  
FAX: (317) 776-5104

#### Dyersburg, Tennessee

Firestone Industrial Products Company  
1901 Sylvan Road  
Dyersburg, TN 38024  
Phone: (901) 286-5054  
FAX: (901) 286-2462

#### Williamsburg, Kentucky

Firestone Industrial Products Company  
One Firestone Boulevard  
P.O. Box 509  
Williamsburg, KY 40769  
Phone: (606) 549-0528  
FAX: (606) 549-0611

#### Sao Paulo, Brazil

Firestone Produtos Industriais Ltda.  
Av. Queiros dos Santos, 1419  
09015 Santo Andre  
Sao Paulo, Brazil  
Phone: 55-11-411-1166  
FAX: 55-11-454-7328

**Firestone**  
World's Number 1  
Air Spring. 

FIRESTONE INDUSTRIAL PRODUCTS COMPANY

Firestone Industrial Products Company • 701 Congressional Boulevard • Carmel, IN 46032-5633  
Telephone: 1-800-AIRIDES • Telephone: 317-580-2300 • Fax: 317-580-2345